

作成承認印

配布許可印



Nikon

COOLPIX S2

VAA36001

REPAIR MANUAL

Nikon | **NIKON CORPORATION**
Tokyo, Japan

Copyright © 2005 by Nikon Corporation.
All Rights Reserved.
無断転載を禁ず !!

CONTENTS

SPECIFICATIONS	M1-M2
DISASSEMBLY	
WARNING	D1
REAR COVER · FRONT COVER UNIT	D2-D3
REMOVAL OF BAND	D4
INNER REAR COVER UNIT	D5
CABINET O-RING	D6
LCD	D6
MONITOR HOLDER	D7
DISCHARGE OF MAIN CONDENSER	D8
INNER FRONT COVER UNIT	D9
PLACE WHICH MUST NOT BE HELD IN LENS UNIT	D9
LENS UNIT	D10
TB-1 PCB	D11
FLASH UNIT	D11
BUTTON TOP UNIT	D12
ASSEMBLY	
TORQUE SCREWDRIVER (J15420)	A1
BUTTON TOP UNIT	A2-A3
FLASH UNIT	A4
TB-1 PCB	A5-A6
PLACE WHICH MUST NOT BE HELD IN LENS UNIT	A6
LENS UNIT	A7
INNER FRONT COVER UNIT	A8
INSTALLATION OF INNER FRONT COVER UNIT	A9-A10
MONITOR HOLDER	A10-A11
LCD	A12
CABINET O-RING	A13
INNER REAR COVER UNIT	A14-A15
INSTALLATION OF BAND	A16
APPLICATION OF GREASE FG-50W	A17
REAR COVER · FRONT COVER UNIT	A18-A19
AIR LEAK TEST	A20-A23
ADJUSTMENT	A24-A35

DISCRIPTION OF CIRCUIT.....E1-E8

ELECTRICITY

OVERALL WIRING E9
 CP1(DMA) CIRCUIT DIAGRAM E10
 CP1(SYA) CIRCUIT DIAGRAM E11
 CP1(PWA) CIRCUIT DIAGRAM..... E12
 CP1(STA) CIRCUIT DIAGRAM E13
 TB1 CIRCUIT DIAGRAM E14
 CA1 CIRCUIT DIAGRAM E15
 ASIC BLOCK DIAGRAM E16
 CCD BLOCK DIAGRAM..... E17
 LENS BLOCK DIAGRAM E18
 OVERALL BLOCK DIAGRAM..... E19
 SYSTEM CONTROL BLOCK DIAGRAM E20
 POWER BLOCK DIAGRAM E21
 FUSE ARRANGEMENT (CP1 PCB) E22

INSPECTION STANDARDS..... R1-R11

TOOL LISTT1-T4

SPECIFICATIONS



Type	COOLPIX S2 digital camera
Effective pixels	5.1 million
CCD	1/2.5" CCD; total pixels: 5.36 million
Image size (pixels)	2,592 × 1,944 (2592*, 2592) 2,048 × 1,536 (2048) 1,024 × 768 (1024) 640 × 480 (640)
Lens	3 × Zoom Nikkor ED lens
Focal length	F=5.8 - 17.4 mm (35-mm [135] camera-format equivalent: 35 - 105 mm)
f/-number	f/3.0 - f/5.4
Construction	12 elements in 10 groups
Digital zoom	Up to 4 × (35-mm [135] camera-format equivalent:420 mm)
Autofocus (AF)	Contrast-detect through the lens (TTL) AF, with AF-assist illuminator
Focus range	30 cm (1') - ∞
(distance from lens)	Macro mode: 4 cm(1.6") - ∞ (middle zoom position)
Focus-area selection	Center; auto multi AF
AF-assist illuminator	Class 1 LED product (IEC60825-1 Edition 1.2 ⁻²⁰⁰¹) Max. output: 2,000 μ W
Monitor	2.5" , 110,000-dot, TFT LCD monitor with brightness adjustment
Approximate frame coverage	Shooting mode: 97% horizontal and 97% vertical Playback: 100% horizontal and 100% vertical
Storage Media	Internal memory (approx.12 MB); SD (Secure Digital) memory cards
File system	Compliant with Design Rule for Camera File System (DCF)*, Exif 2.2 ⁺ , and Digital Print Order Format (DPOF)
File formats	Compressed: JPEG-baseline-compliant Movies: QuickTime Sound files: WAV
Exposure	
Metering	256-segment matrix metering linked to AF area
Exposure control	Programmed auto exposure with exposure compensation (-2.0 - +2.0 EV in steps of 1/3 EV)
Range	W: +1.2 - +15.2 EV T: +2.9 - +17.3 EV
Shutter	Mechanical and charge-coupled electronic shutter
Speed	2 - 1/350 s
Aperture	Electronically-controlled ND-filter selection
Range	Two steps (f/3.0 and f/8.5 [W])
Sensitivity	Approximately equivalent to ISO 50, 100, 200, 400; Auto
Self-timer	Approximately 10 seconds

Built-in flash	
Range (approx.)	W: 0.3 - 2.5 m/1' - 8'2" T: 0.3 - 1.4 m/1' - 4'7"
Sync method	Sensor flash system
Interface	USB
Video output	Can be selected from NTSC and PAL
I/O terminals	Multi connector
Life waterproof JIS	IPX4 (according to our company's test conditions)
Supported languages	Chinese (Simplified and Traditional), Dutch, English, French, German, Italian, Japanese, Korean, Russian, Spanish, Swedish
Power sources	<ul style="list-style-type: none"> • One rechargeable Nikon EN-EL8 lithium-ion battery (supplied) • EH-63 AC adapter (supplied)
Battery life	Approximately 190 shots (EN-EL8; based on CIPA standard *)
Dimensions (W × H × D)	91.9 × 59 × 22 mm/3.6" × 2.3" × 0.8" (W × H × D)
Approximate weight	140 g (4 oz) without battery or memory card
Operating environment	
Temperature	0 - 40 °C (32 - 104 °F)
Humidity	Less than 85% (no condensation)

* Industry standard for measuring life of camera batteries. Measured at 25 °C (77 °F); zoom adjusted with each shot, flash fired with every other shot, image mode set to NORMAL.

Unless otherwise stated, all figures are for a camera with a fully-charged EN-EL8 battery operated at an ambient temperature of 25 °C (77 °F).

DISASSEMBLY

 WARNING	
	<ul style="list-style-type: none">● There are high voltage parts inside. Be careful of this electric shock, when you remove the cover.● You must discharge the main condenser according to the instruction of this repair manual after you remove the cover.

Points to notice for Lead-free solder products
<ul style="list-style-type: none">▪ Lead-free solder is used for this product.▪ For soldering work, the special solder and soldering iron are required.▪ Do NOT mix up lead-free solder with traditional solder.▪ Use the special soldering iron respectively for lead-free solder and lead solder. They cannot be used in common.

- Note :
- ① Before disassembling, remove the SD card and the charged battery.
 - ② When disassembling, make sure to memorize the processing state of wires, screws to be fixed and their types, etc.
 - ③ Because electrical parts are easily damaged by static electricity, make sure that you are well earthed/grounded.

REAR COVER • FRONT COVER UNIT

- Remove the four screws [#101].



- Remove the three screws [#101].

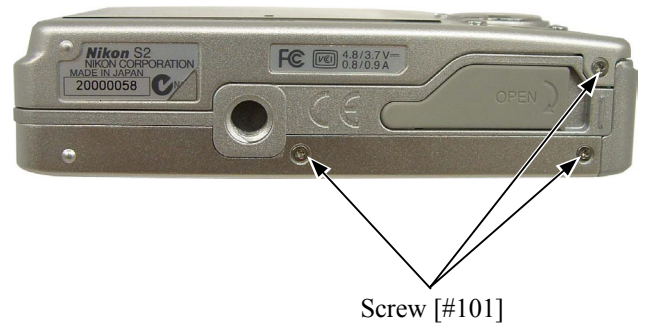

- Remove the two screws [#101].



- Remove the front cover unit [#001].



- Open the rear cover [#046] as unhooking its top section and then remove its bottom section.

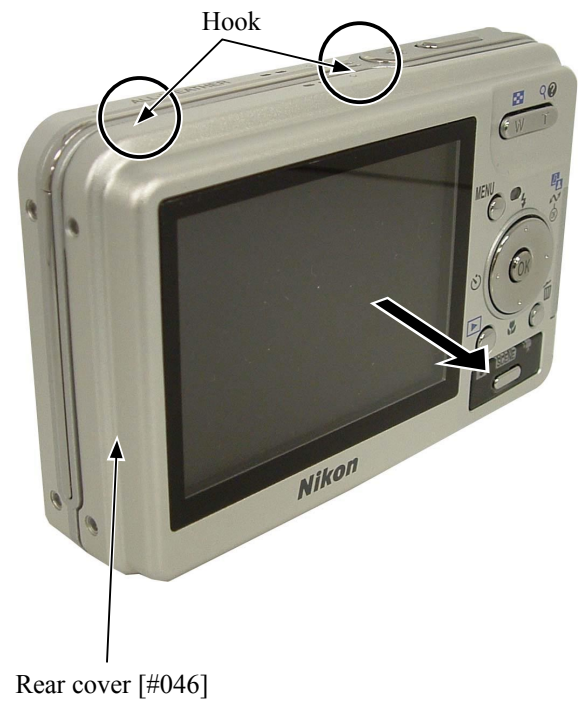

Note: When you do not replace the shaft strap [#016], the power LED window [#235] and the button ornament [#238] with new ones, it is not necessary to disassemble the unit as shown below.

REMOVAL OF BAND

- Remove the shaft strap [#016].
- Remove the button ornament [#238].
- ※ The button ornament is adhered with the double-adhesive tape. (2 places)
- Remove the power LED window [#235].



- Remove the joint holder [#231] as releasing it from the bosses (2 places).
- Remove the joint top holder [#232] as releasing it from the bosses (2 places).

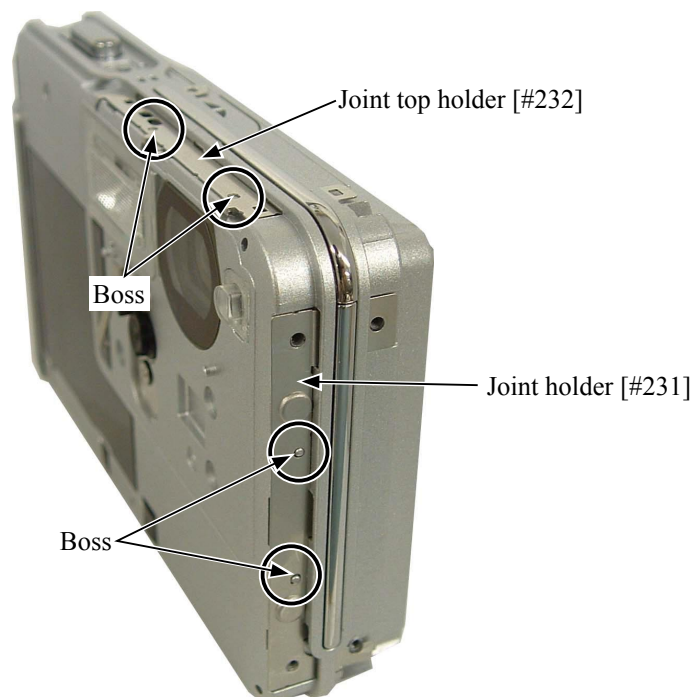

INNER REAR COVER UNIT

- Remove the screw [#103]. (The O-ring [#048] can also be removed.)

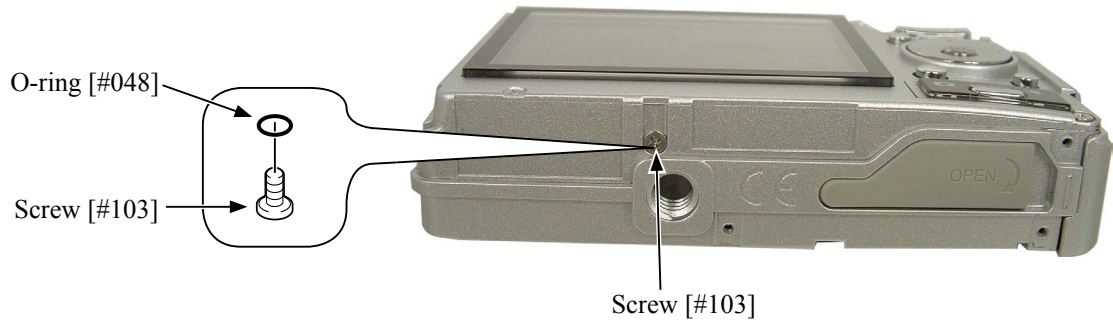

- Remove the screw [#105]. (The O-ring [#048] can also be removed.)
- Remove the two screws [#103].
- Remove the two screws [#104].



- Open the battery cover unit [#037].
- Remove the inner rear cover unit [#020].
- ※ It is sometimes difficult to remove the cover. Remove it a little strongly as taking care for the FPC at the bottom.
- Remove the FPC.

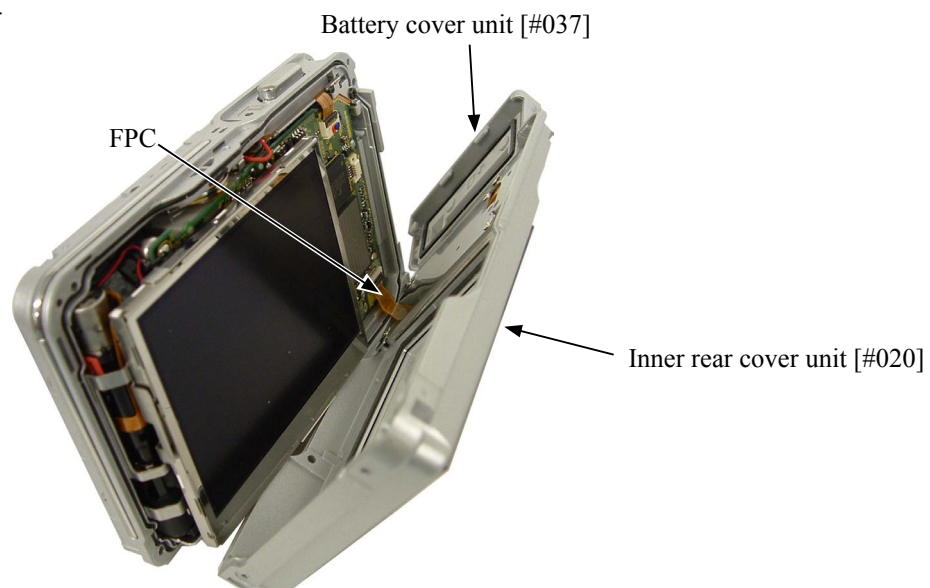

CABINET O-RING

Note: The cabinet O-ring [#047] cannot be reused. After removing the cabinet O-ring, replace it with a new one.

- Remove the cabinet O-ring [#047].

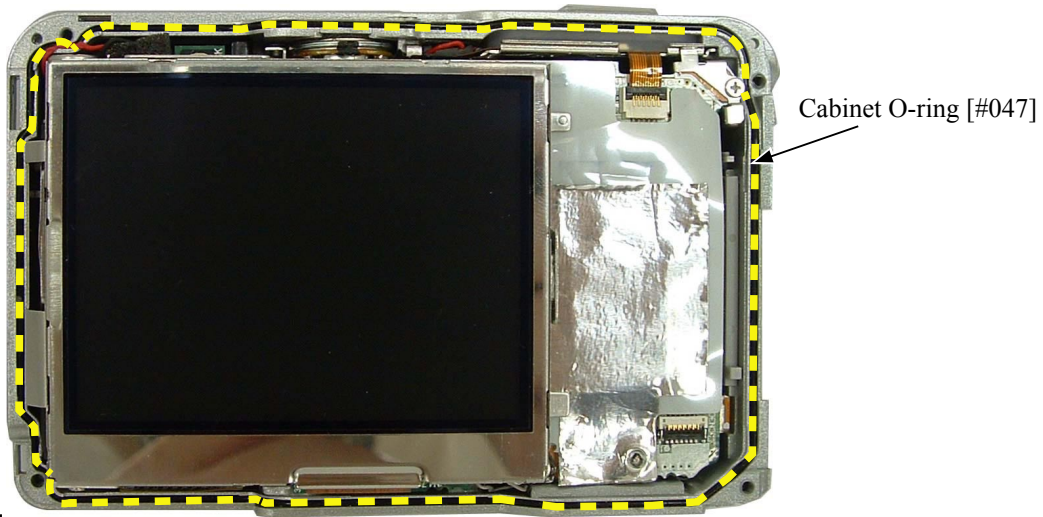

LCD

- Unhook the LCD [#019] and lift it up.

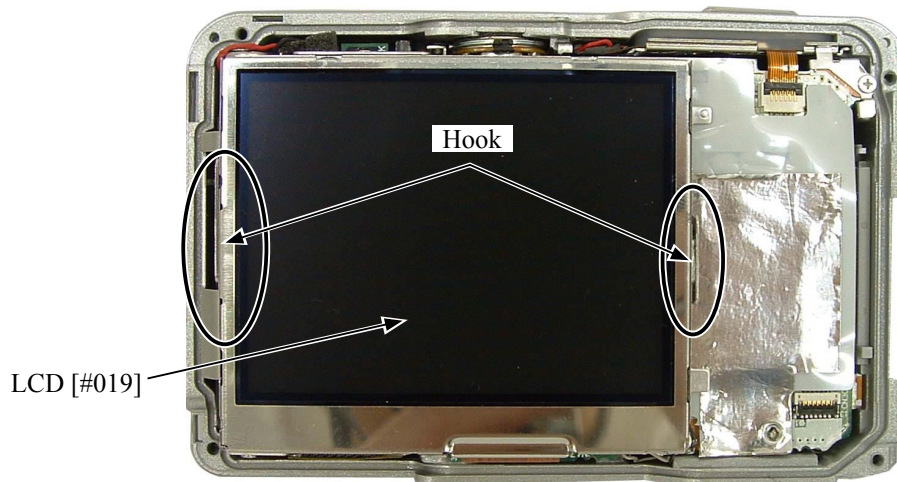

- Remove the connector.
- Remove the FPC.

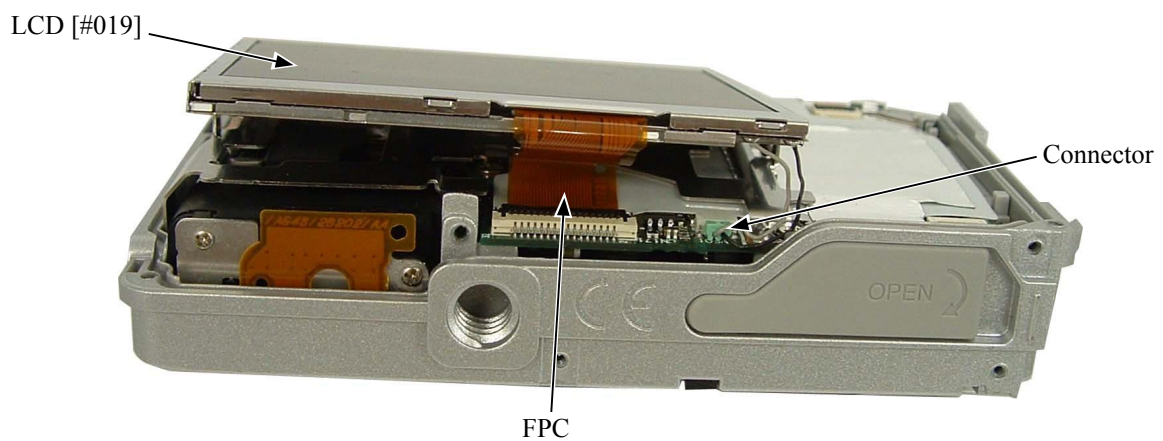

MONITOR HOLDER

- Remove the two screws [#110].
- The spacer [#262] can be removed.

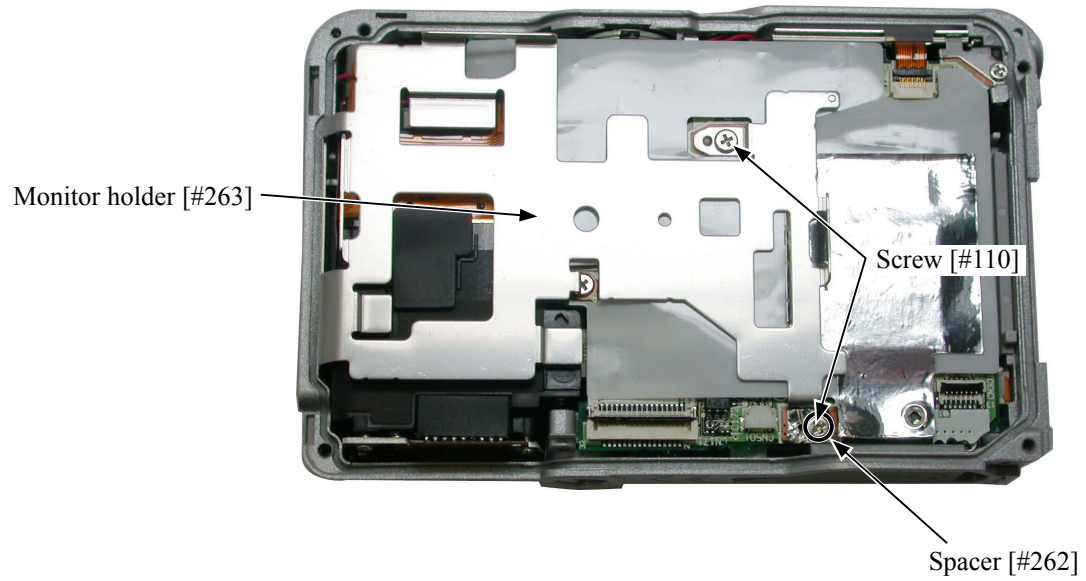

- Remove the two screws [#105].
- ※ The O-ring [#048] can also be removed.
- Remove the monitor holder [#263].

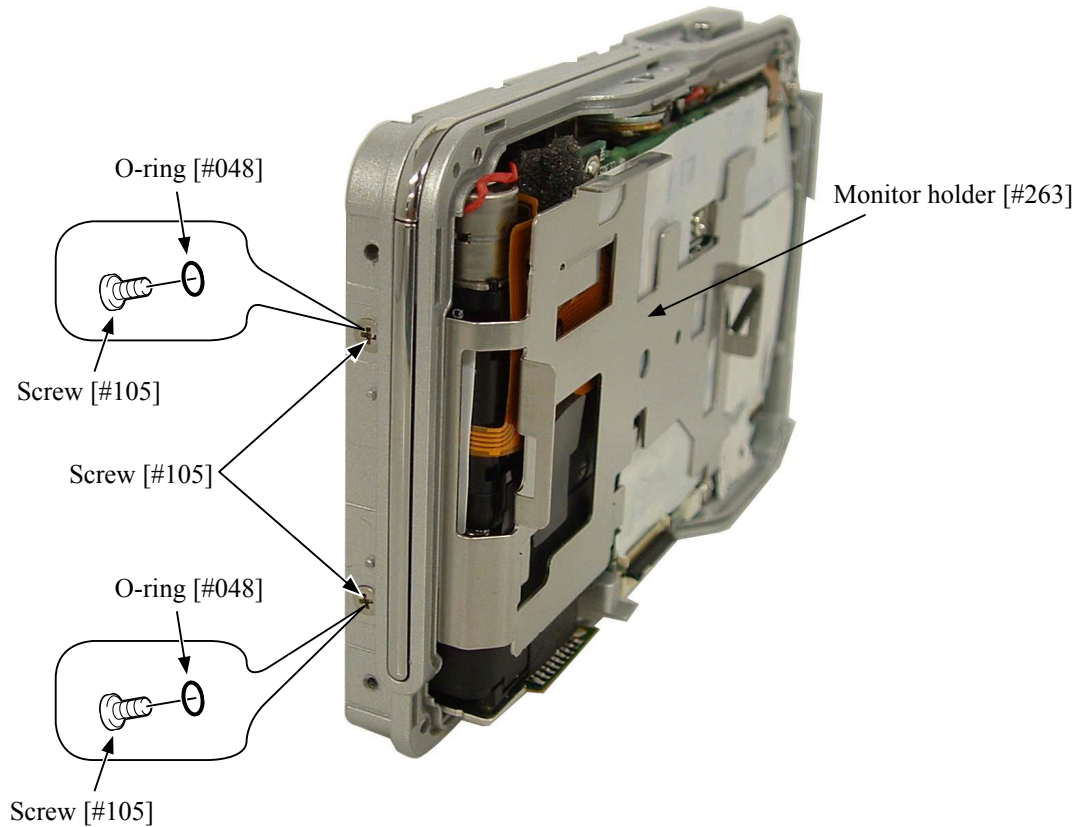

⚠ WARNING

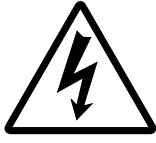

- There are high voltage parts inside. Be careful of this electric shock, when you remove the cover.
- You must discharge the main condenser according to the instruction of this repair manual after you remove the cover.

DISCHARGE OF MAIN CONDENSER

- Take off the shield tape [#261].

Shield tape [#261]

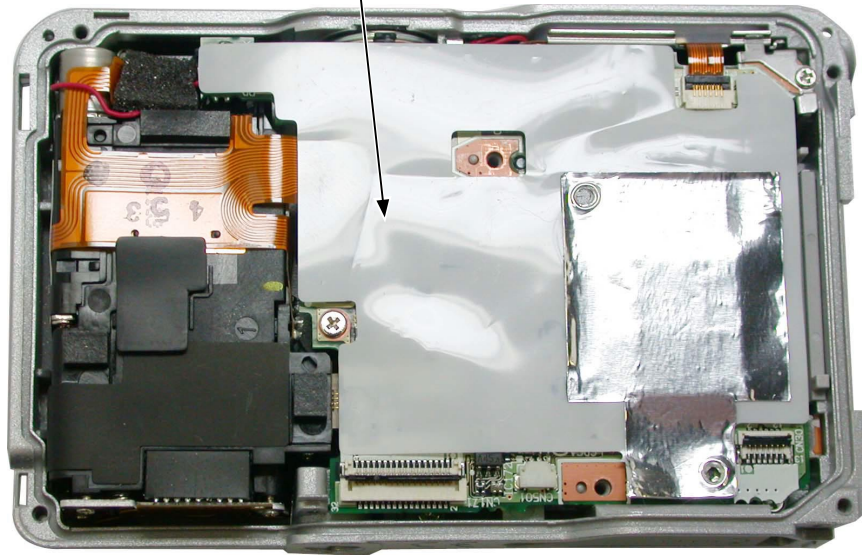

- Perform discharging.

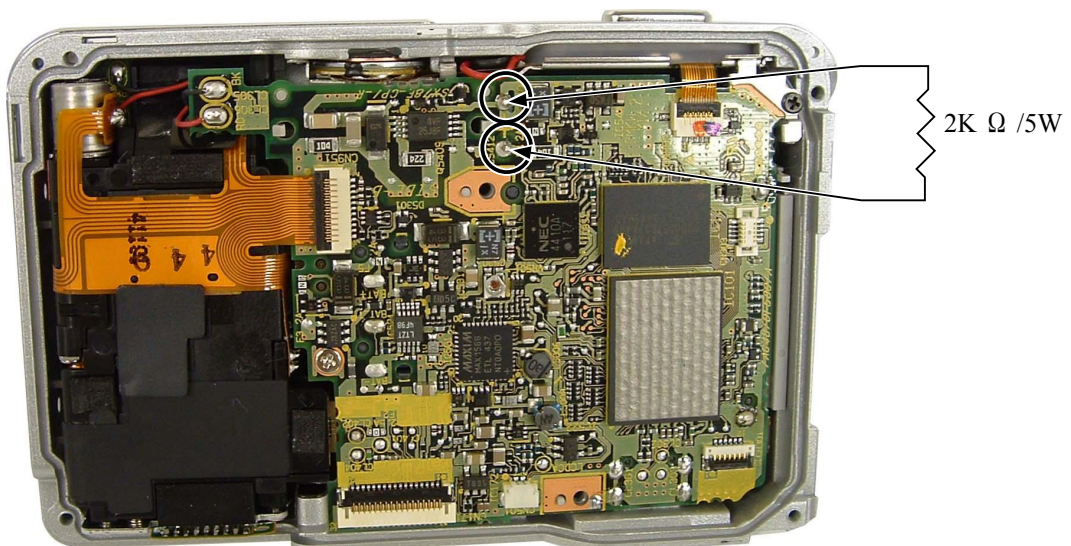

INNER FRONT COVER UNIT

- Remove the FPC.
- Remove the screw [#109].
- Remove the earth plate [#259].
- Remove the screw [#110].
- Remove the lens unit [#246] and the main PCB unit CP-1 [#257] from the inner front cover unit [#201].

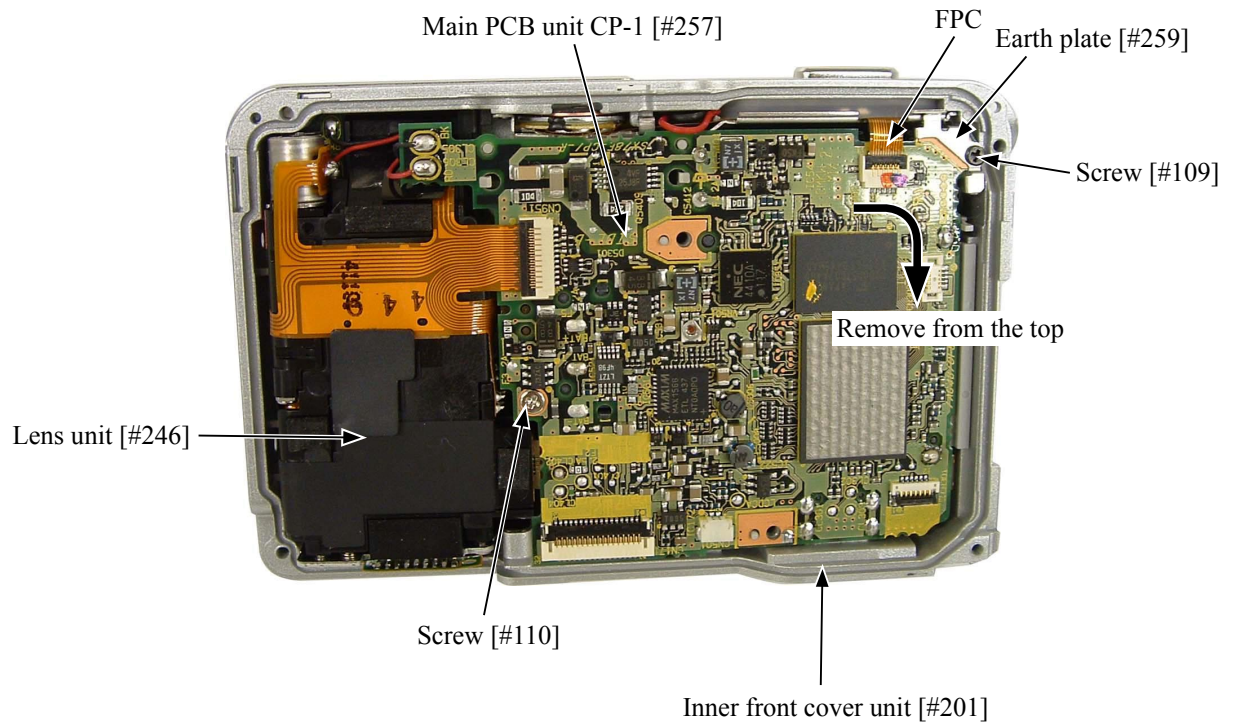

PLACE WHICH MUST NOT BE HELD IN LENS UNIT

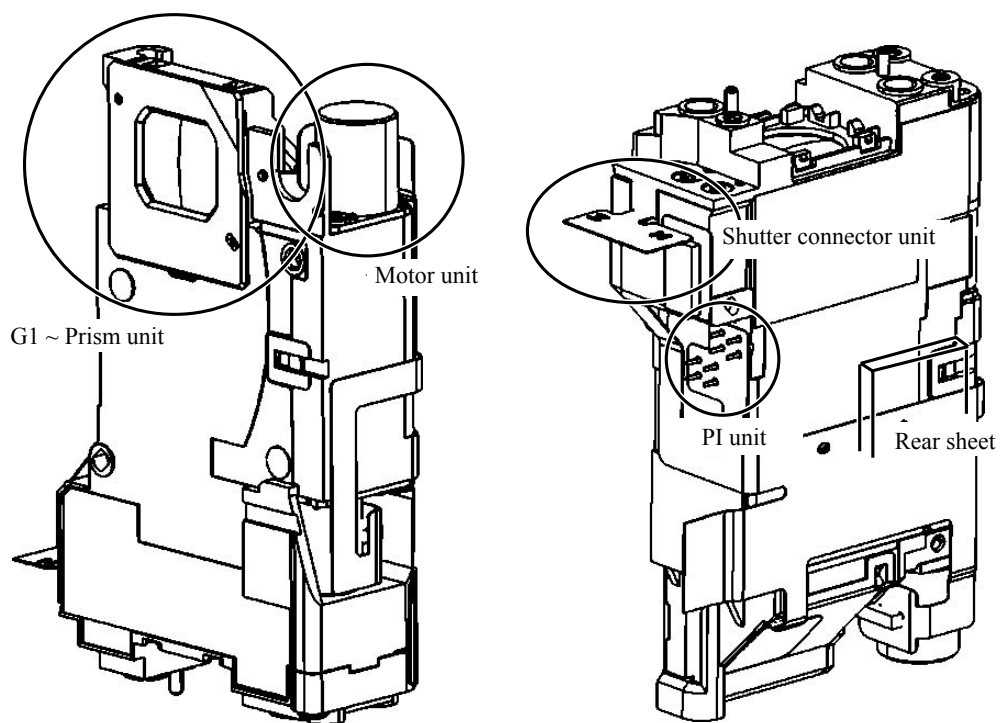

LENS UNIT

- Take off the spacer [#255].

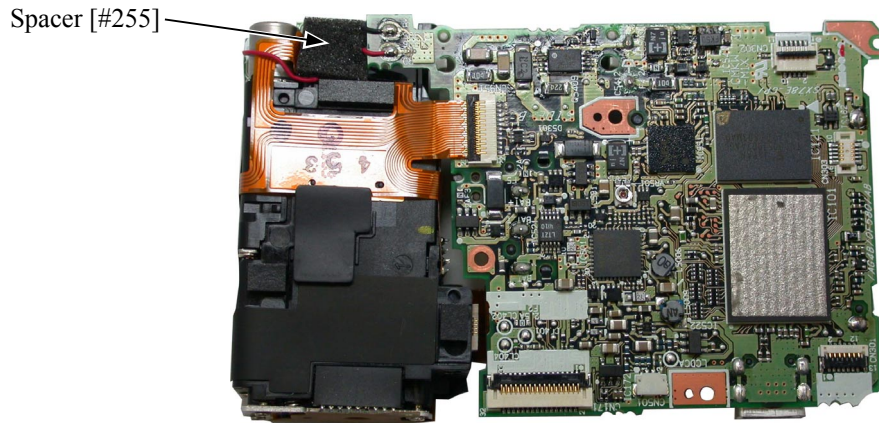

- Unsolder the lead wires [red] and [black].
- Remove the FPC. (Back surface)
- Remove the FPC. (Front surface)
- Remove the lens unit [#246] from the main PCB unit CP-1 [#257].

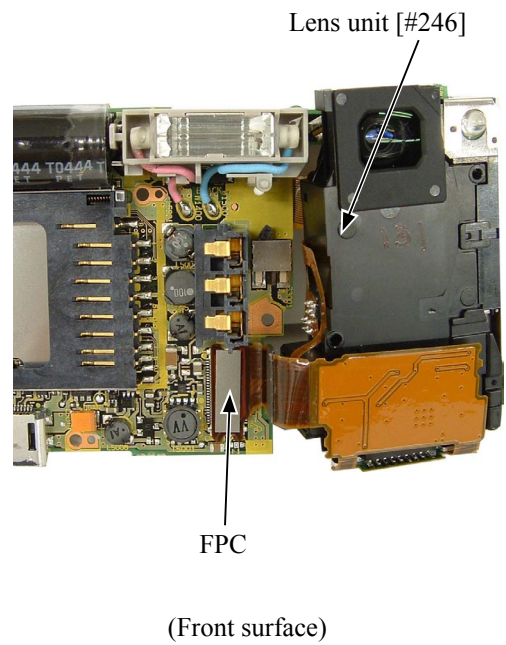
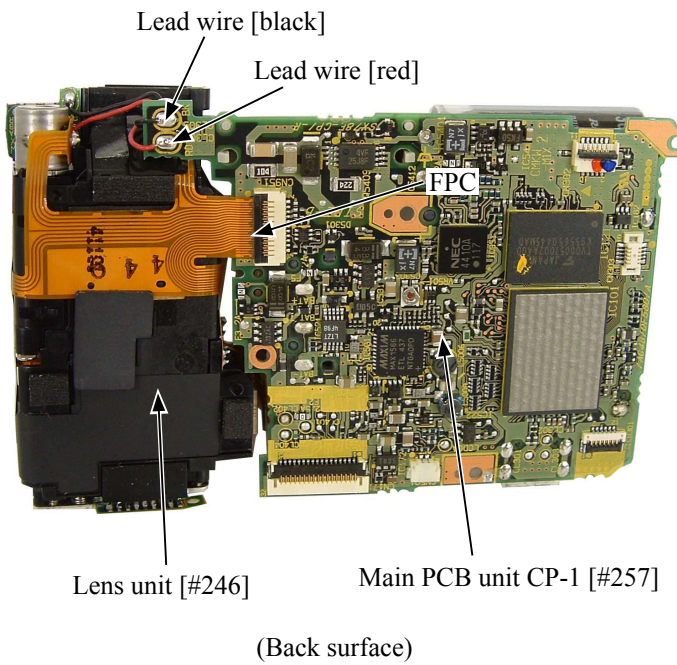

TB-1 PCB

- Remove the spring [#254] as releasing it from the bosses.
- Remove the LED PCB unit TB-1 [#253].
- Remove the spacer (LED) [#252] from the LED PCB unit TB-1 [#253].

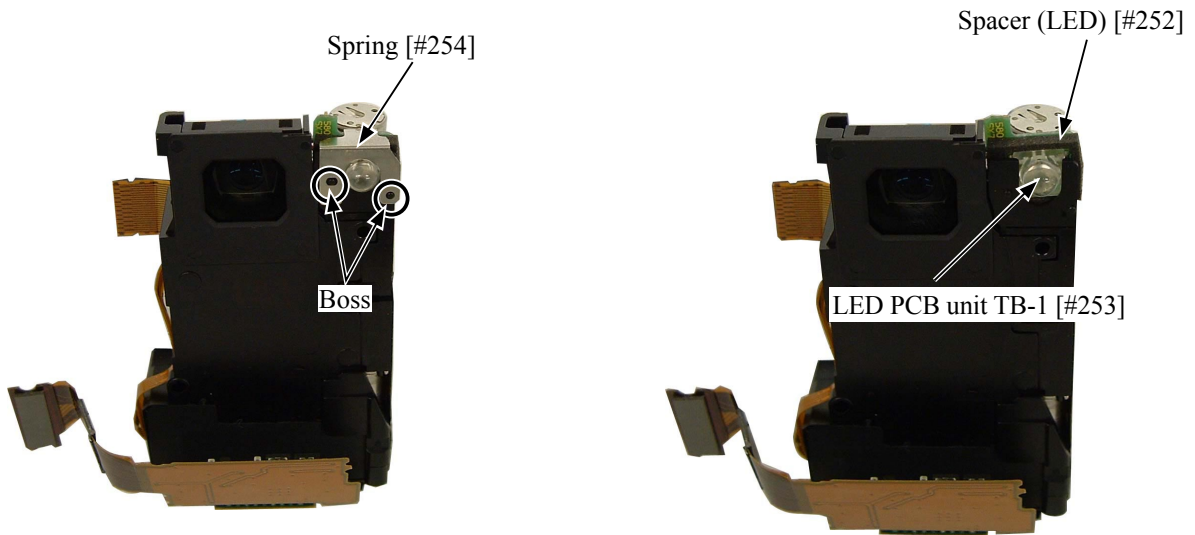

FLASH UNIT

- Unsolder the lead wires [pink] and [blue].
- Perform unhooking and remove the bosses. Then, remove the flash unit [#260]. (Back surface)

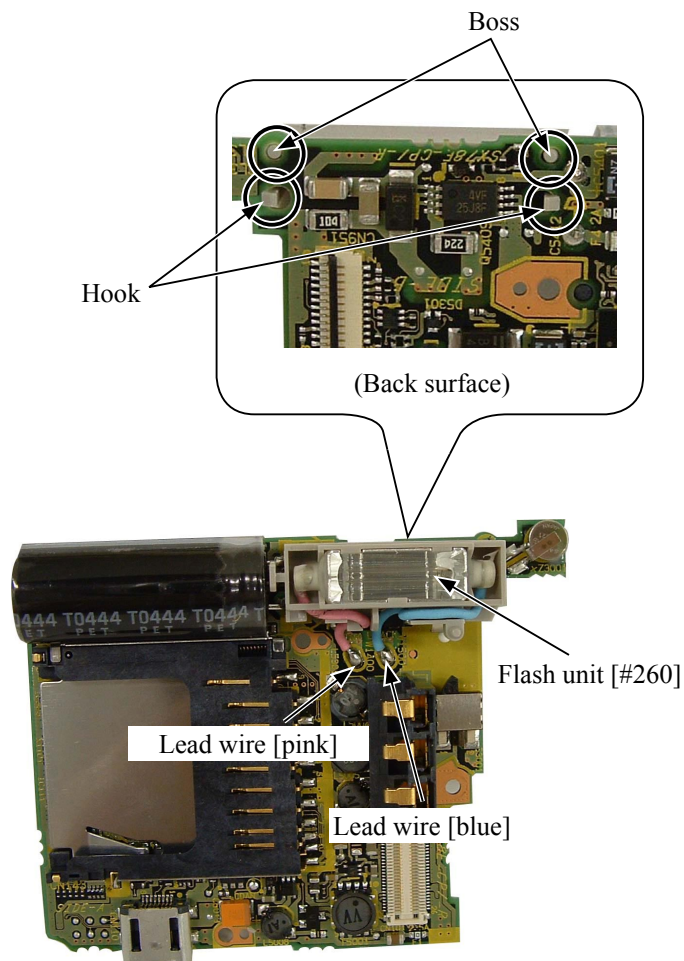

BUTTON TOP UNIT

- Remove the screw [#105].
- ※ The O-ring [#048] can also be removed.

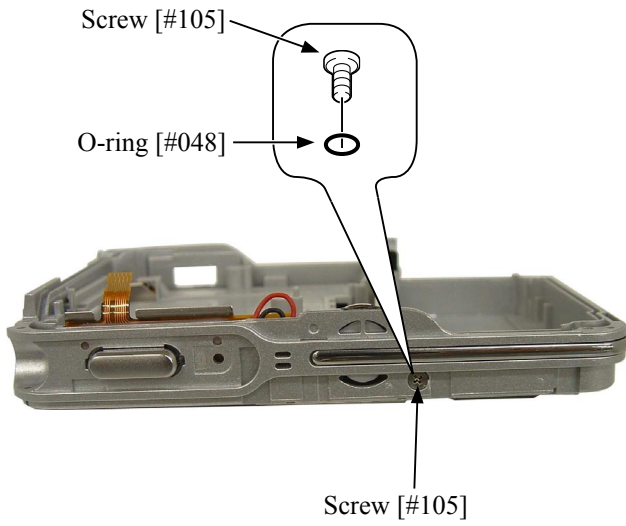

- Remove the button top unit [#239] by sliding it to your side.
- Remove the speaker [#241] and the microphone [#242].

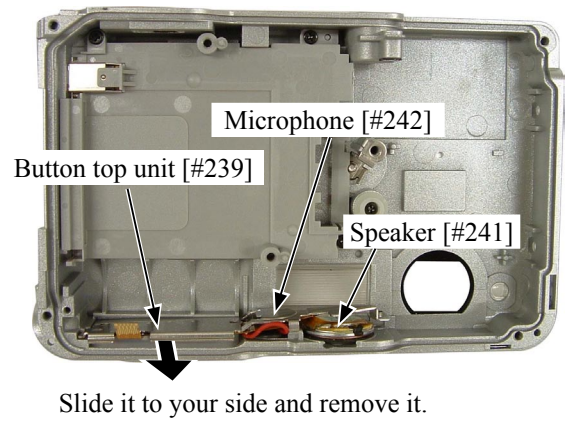

- Remove the pad top [#243].

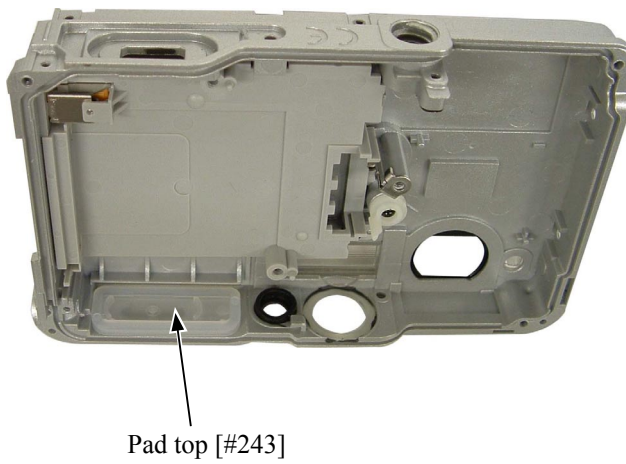

- Remove the release button [#245].

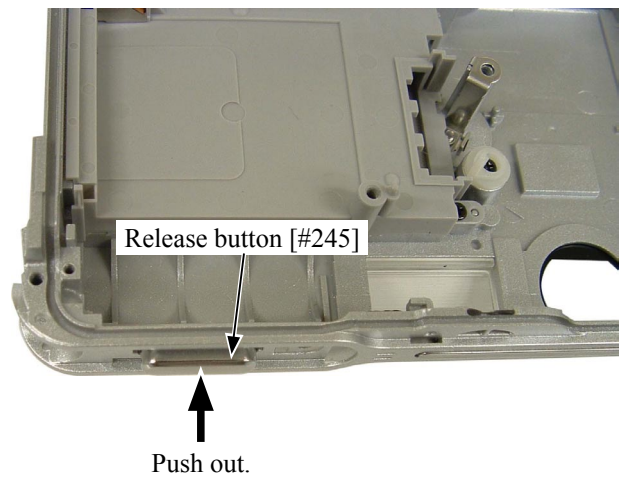

ASSEMBLY

TORQUE SCREWDRIVER (J15420)

Note: The torque screwdriver (J15420) is necessary to mount the monitor holder [#263] and the inner rear cover unit [#020].

For the details of the using method for the torque screwdriver (J15420), refer to its accompanying instruction manual.

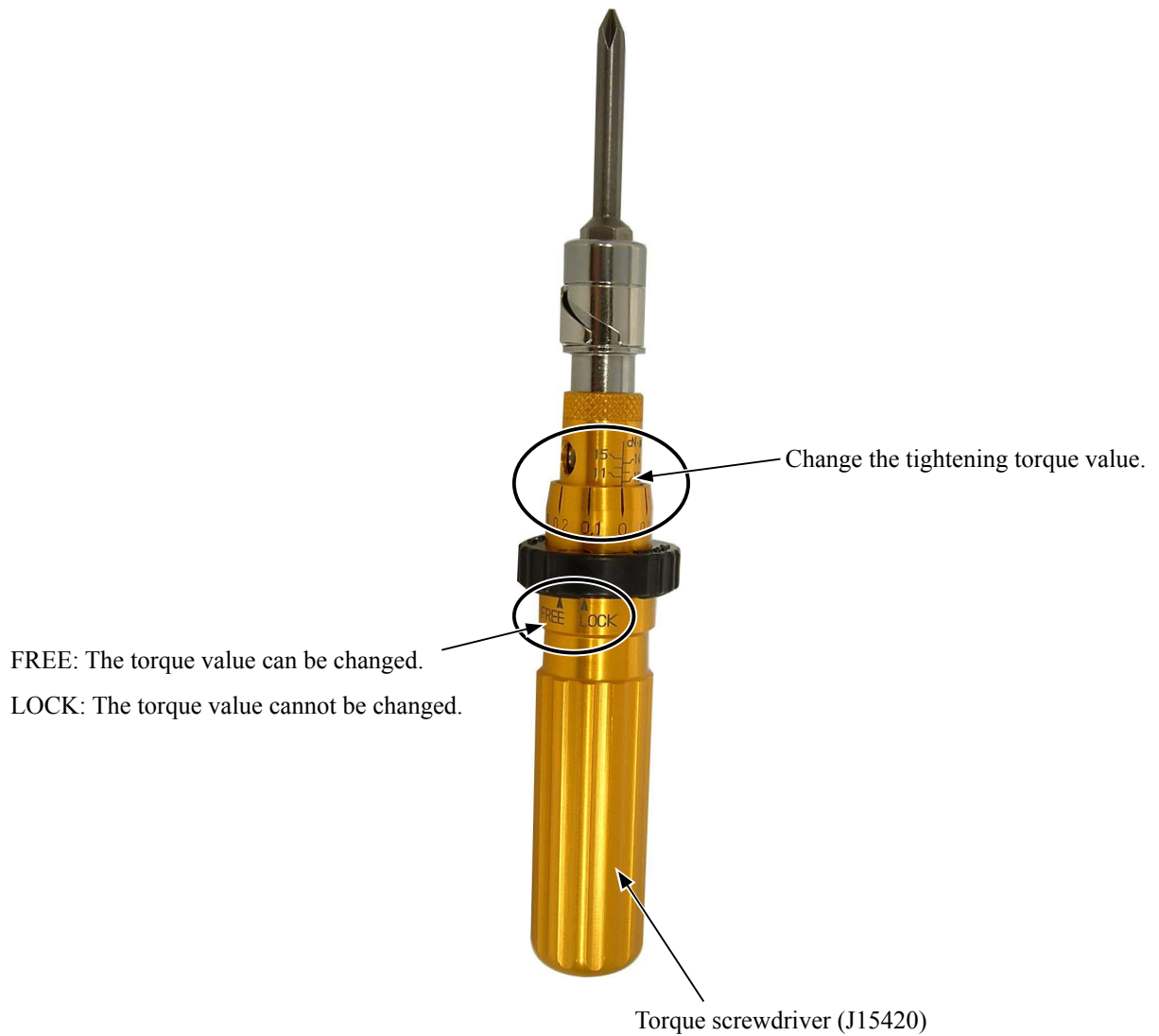

BUTTON TOP UNIT

- Mount the release button [#245].

- Mount the pad top [#243] by fitting its bosses.

※ Unless the bosses of the pad top [#243] are fitted into the holes of the inner front cover unit [#201] normally, the release button cannot be pressed smoothly.

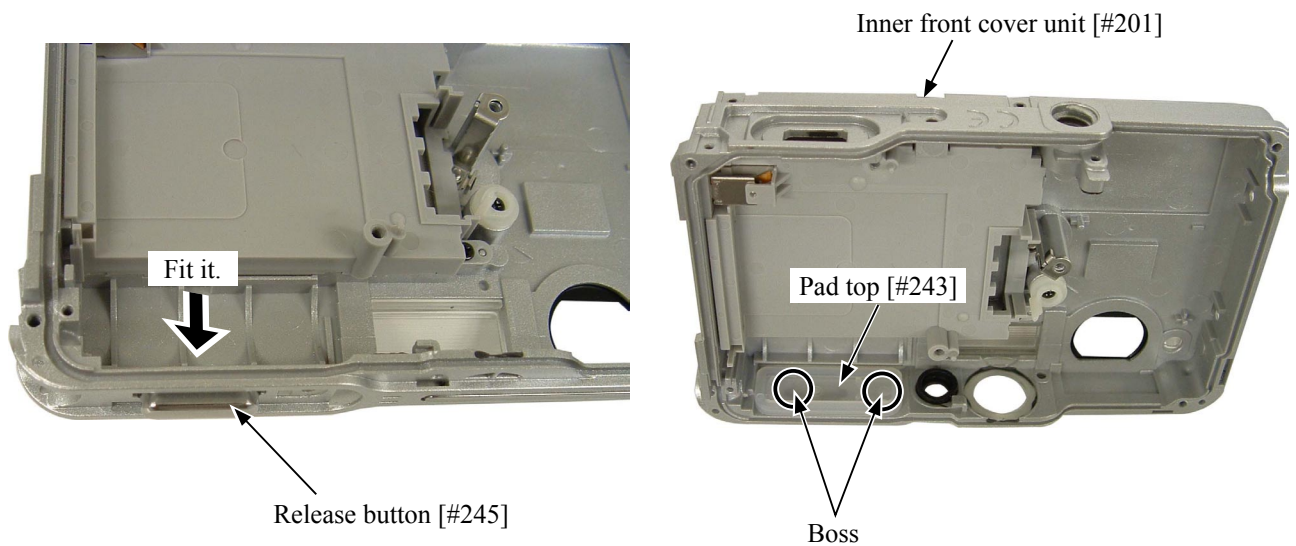

- Insert the section "A" of the button top unit [#239] and the speaker [#241] into the sections "B" and "C" of the inner front cover unit [#201] respectively. Then, fix them.

※ Make sure that the FPC of the speaker [#241] is set into the section "C".

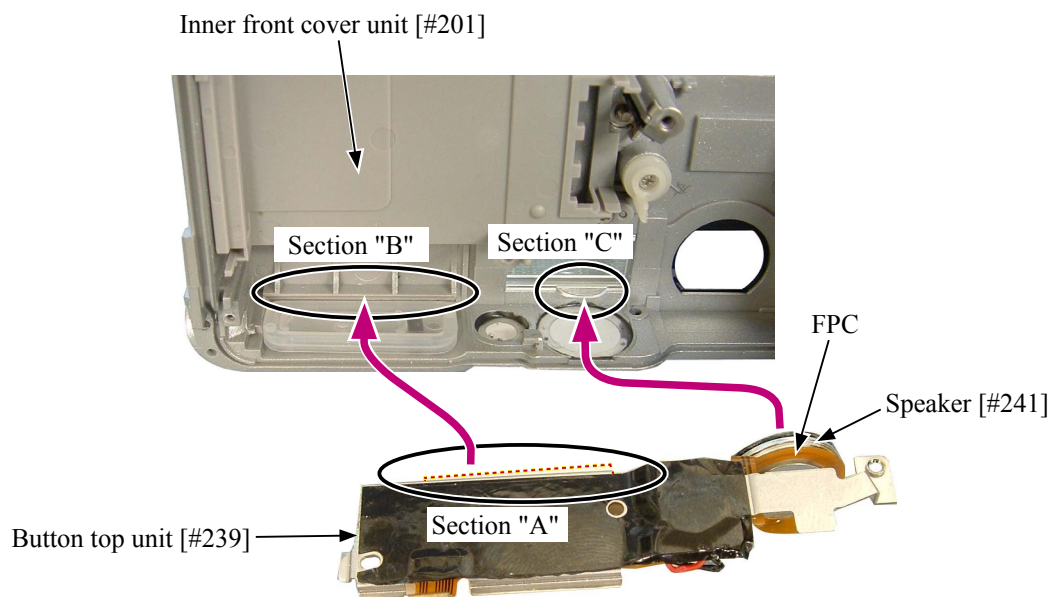

- As holding the button top unit [#239] from above, insert the sections "D" and "F" into the sections "E" and "G" of the inner front cover unit [#201] respectively.

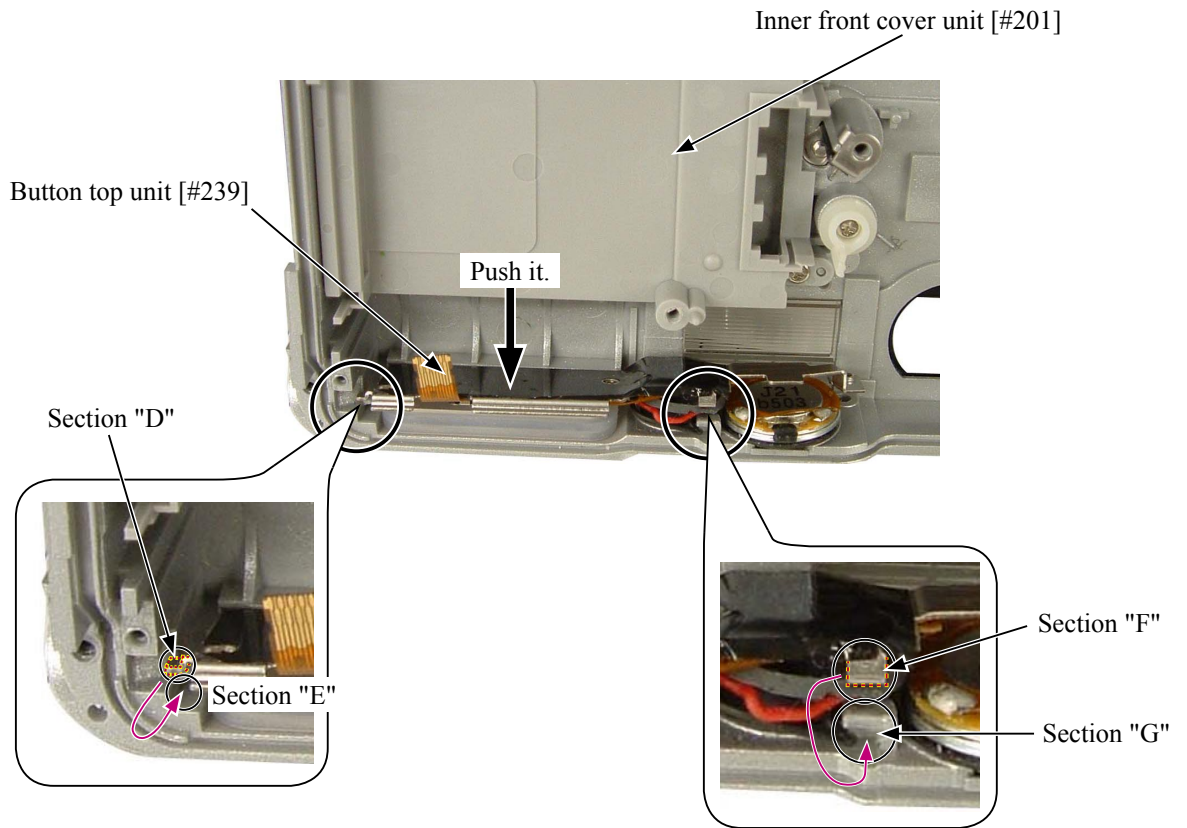

- Fit the O-ring [#048] to the screw [#105] and tighten it.

Note: The tightening torque value is set for the screw [#105]. Tighten the screw according to the set torque value. (The tightening torque affects the waterproof function.)
 The O-ring [#048] cannot be reused. Replace it with a new one.

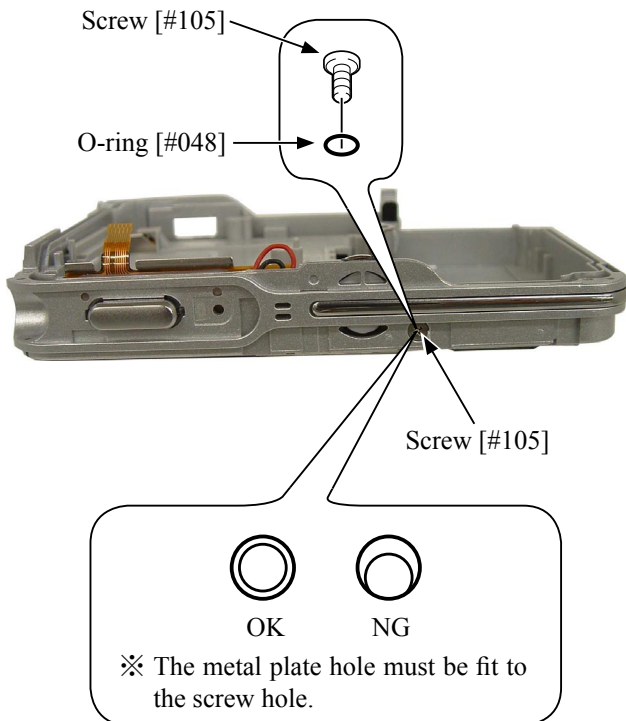

<Tightening torque>

	When assembling newly	When reassembling
Screw [#105]	12cN · m	12cN · m

Note:
 In case the part, which is attached with the screw and O-ring, is replaced, tighten the screw and O-ring by the torque for assembling.
 In the other cases, tighten them by the torque for reassembling.

FLASH UNIT

- Mount the flash unit [#260] by fitting its bosses to the main PCB unit CP-1 [#257] and perform hooking. (Back surface)
- Solder the lead wires [pink] and [blue].

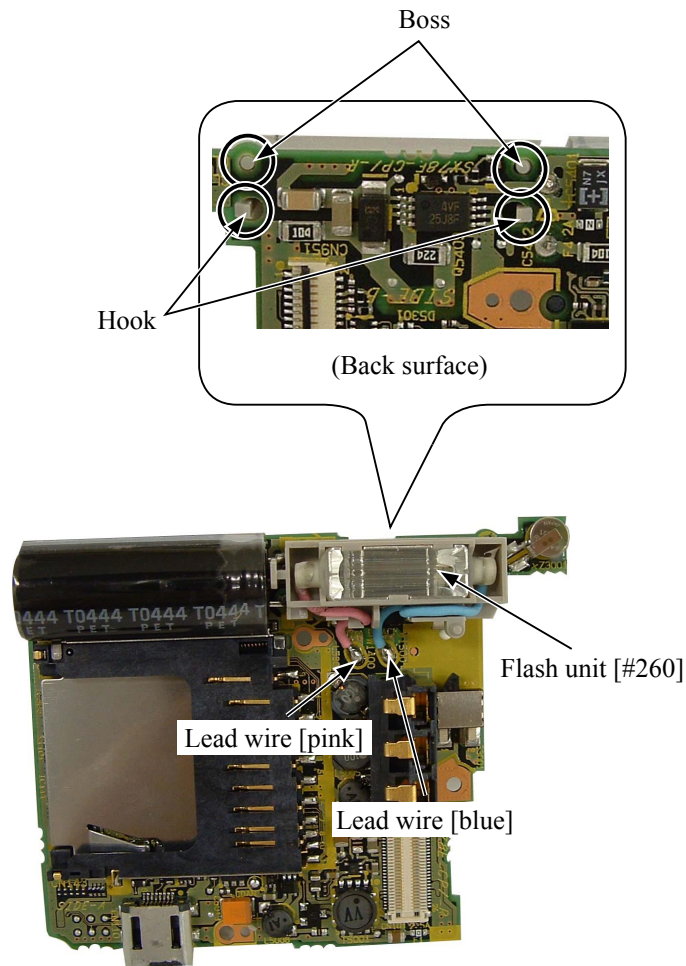

TB-1 PCB

- Mount the spacer (LED) [#252] onto the LED PCB unit TB-1 [#253].

※ Be careful for the mounting direction.

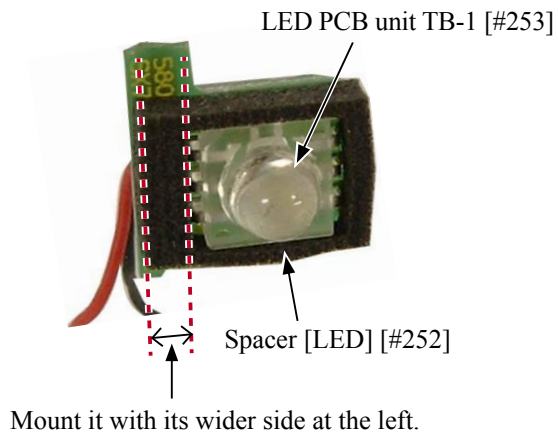

- Mount the LED PCB unit TB-1 [#253].

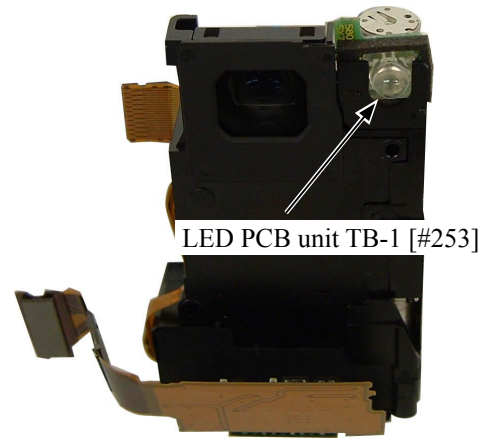

- Mount the spring [#254].

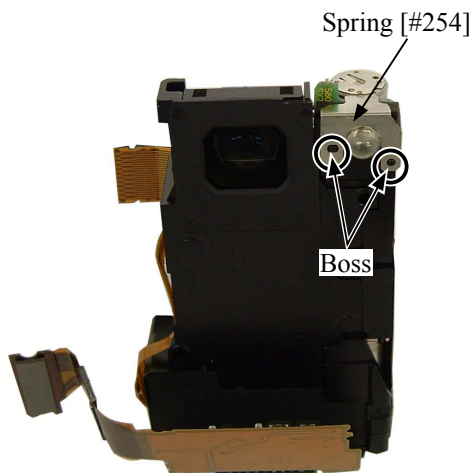

Note: Before replacing the lens unit [#246] or the main PCB unit CP-1 [#257] with a new one, be sure to record the value. This value is used for adjusting the lens after assembly.

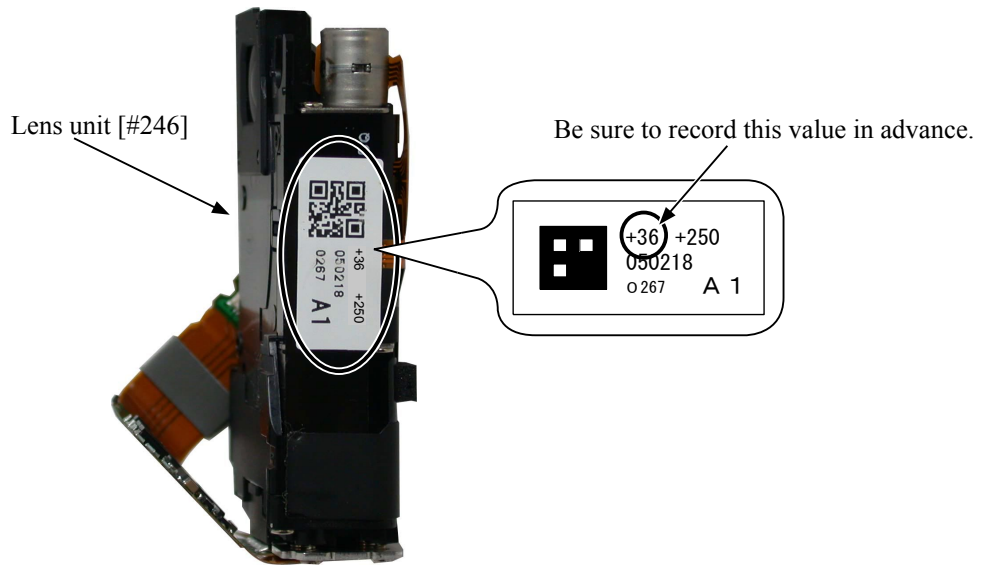

PLACE WHICH MUST NOT BE HELD IN LENS UNIT

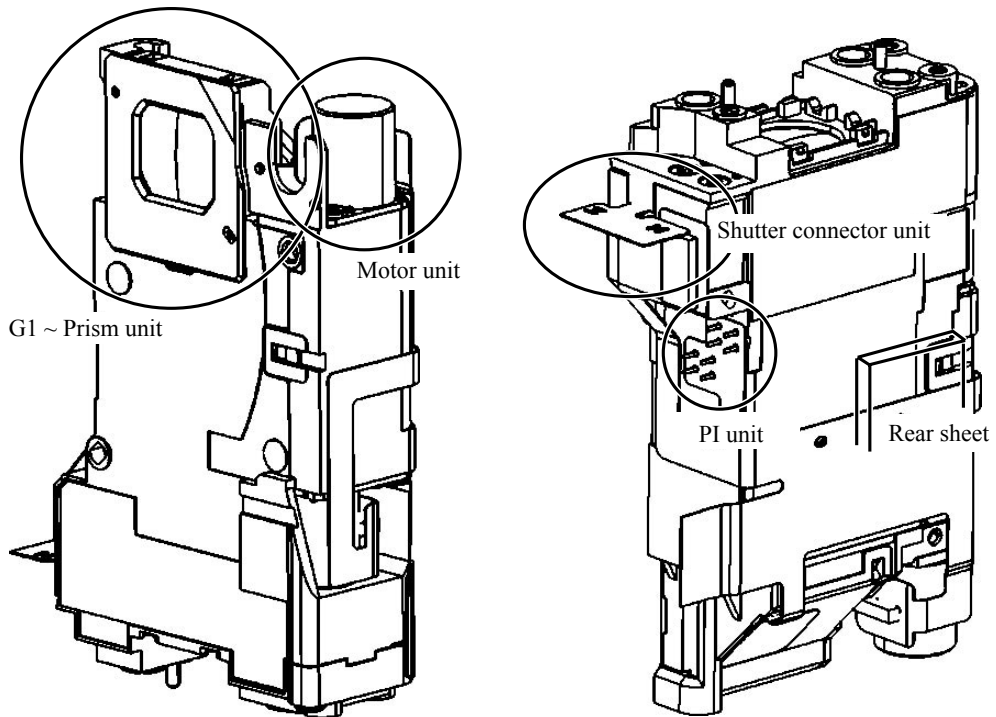

LENS UNIT

- Solder the lead wires [red] and [black].
- Mount the FPC (front surface).
- Mount the FPC (back surface).

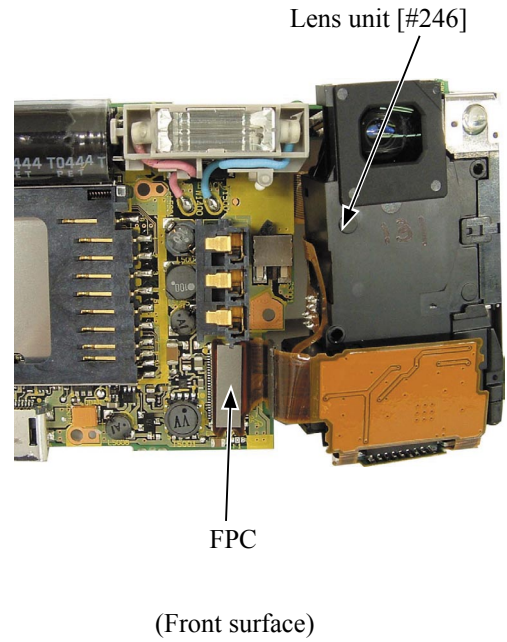
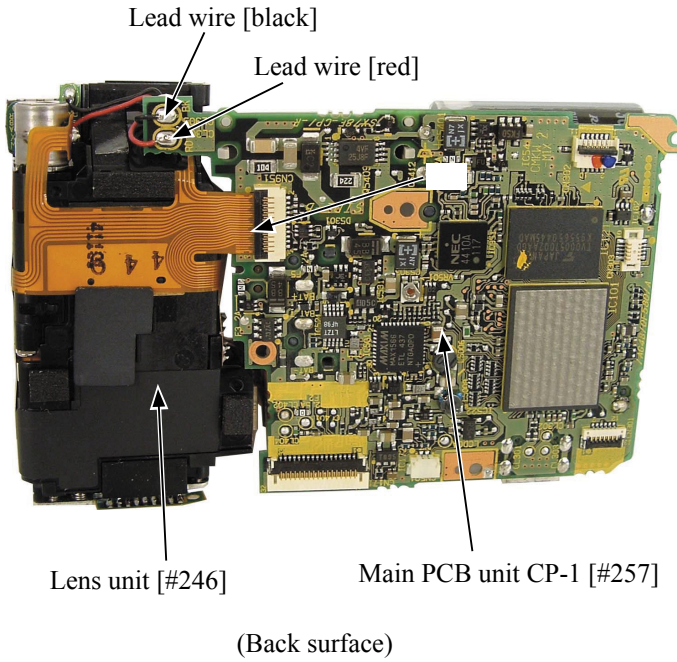

- Adhere the spacer [#255].

Adhering position of spacer [#255]

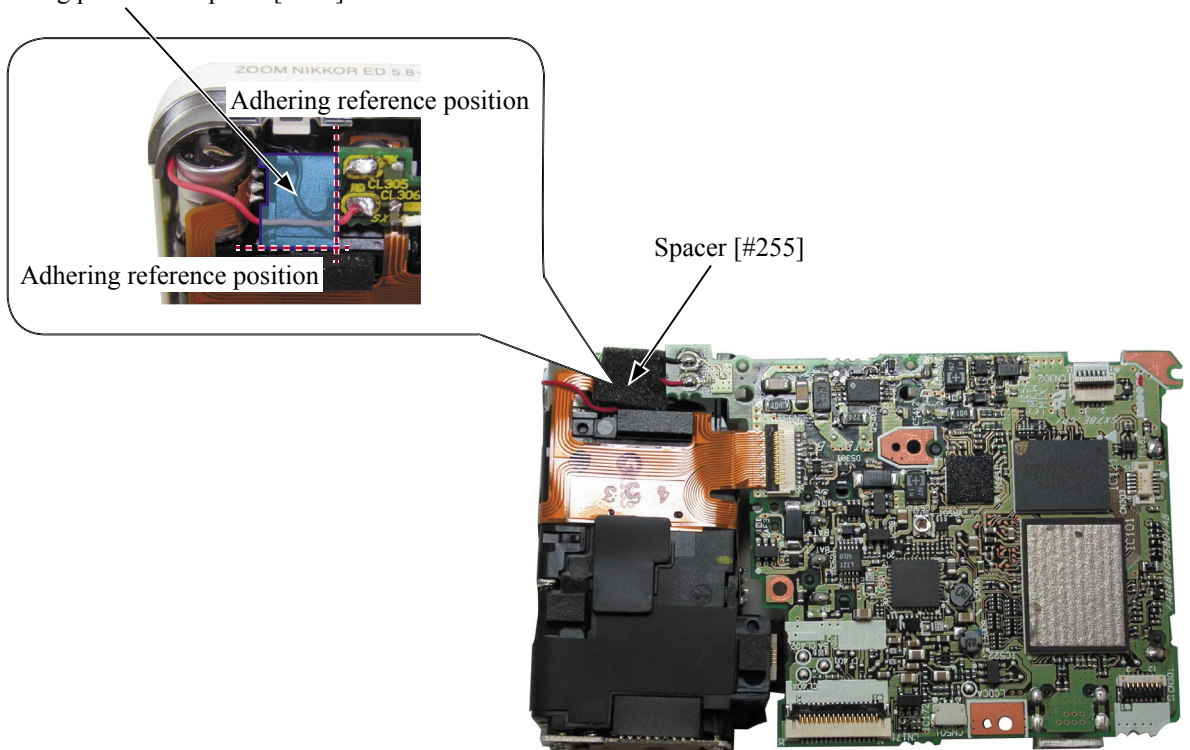

INNER FRONT COVER UNIT

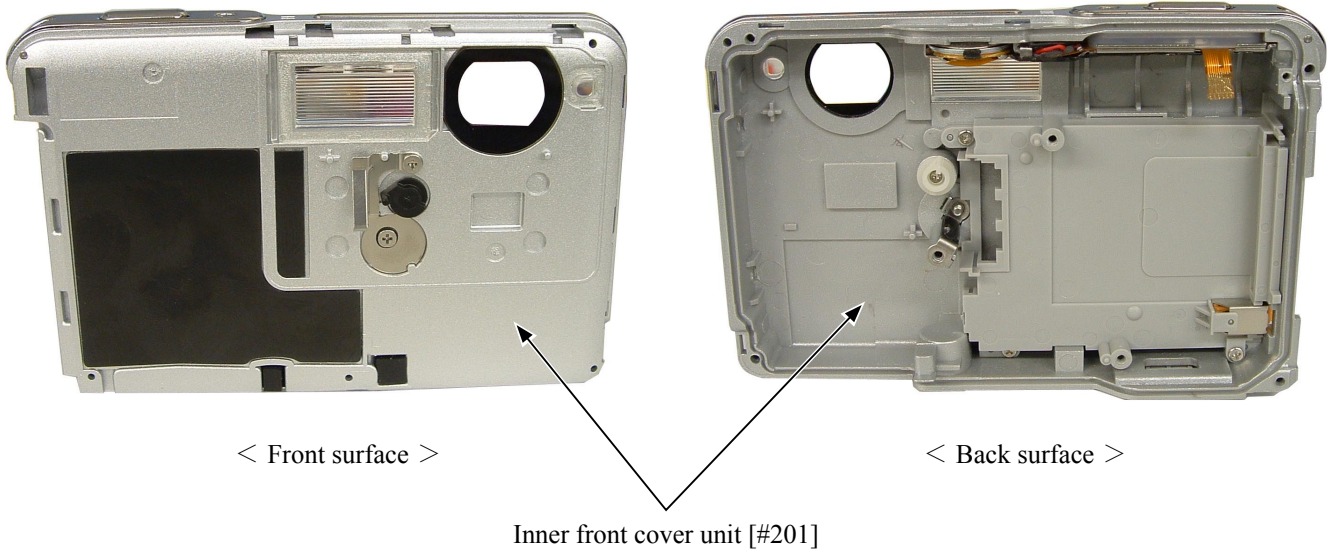

INSTALLATION OF INNER FRONT COVER UNIT

- Make sure that the sensor lever [#207] aligns to the mark position.

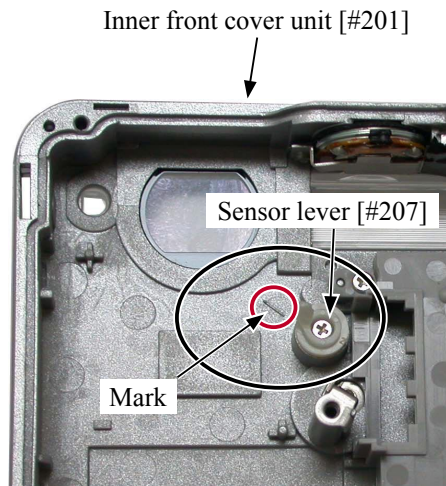

- Put the multi-connector terminal of the main PCB unit CP-1 [#257] into the inner front cover unit [#201]. As taking care not to catch the FPC, mount the lens unit [#246] and the main PCB unit CP-1 [#257] onto the inner front cover unit [#201].

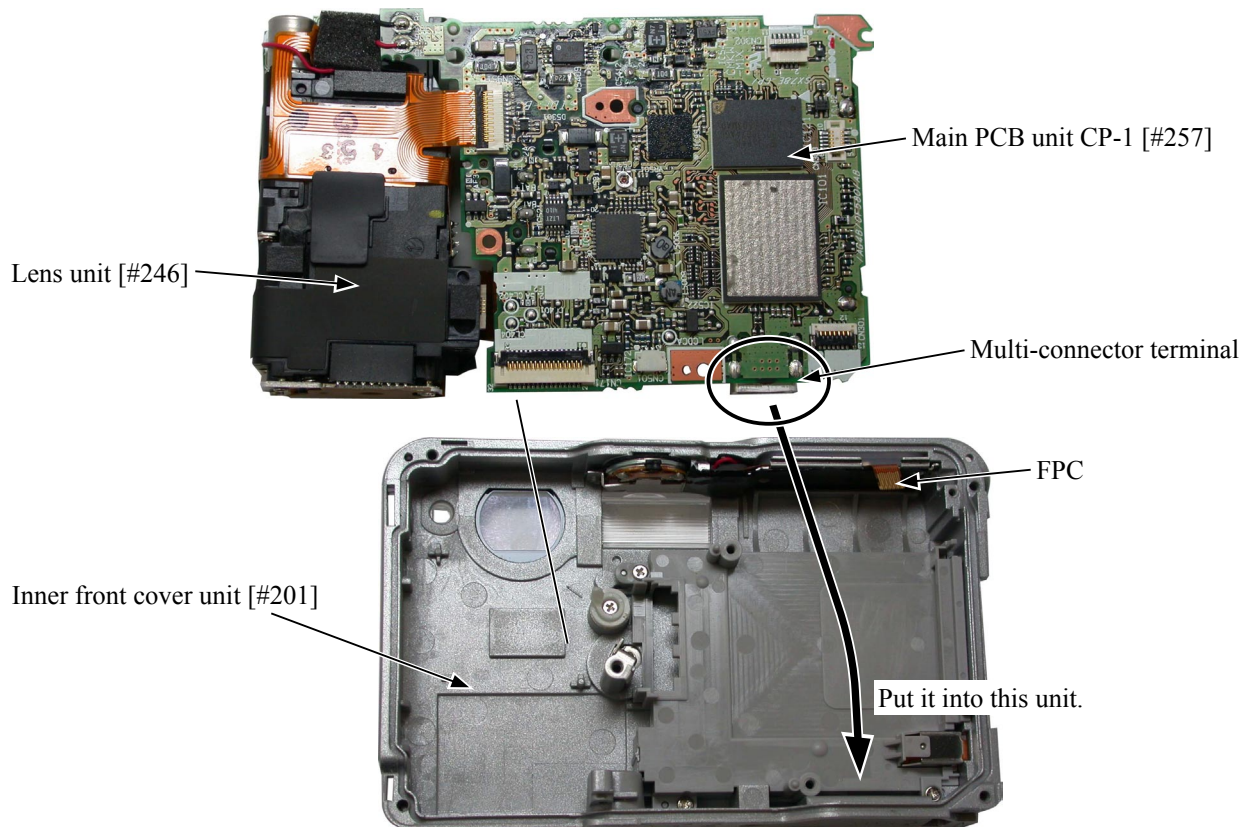

- Tighten the screw [#110].
- Mount the earth plate [#259] and tighten the screw [#109].
- Mount the FPC.

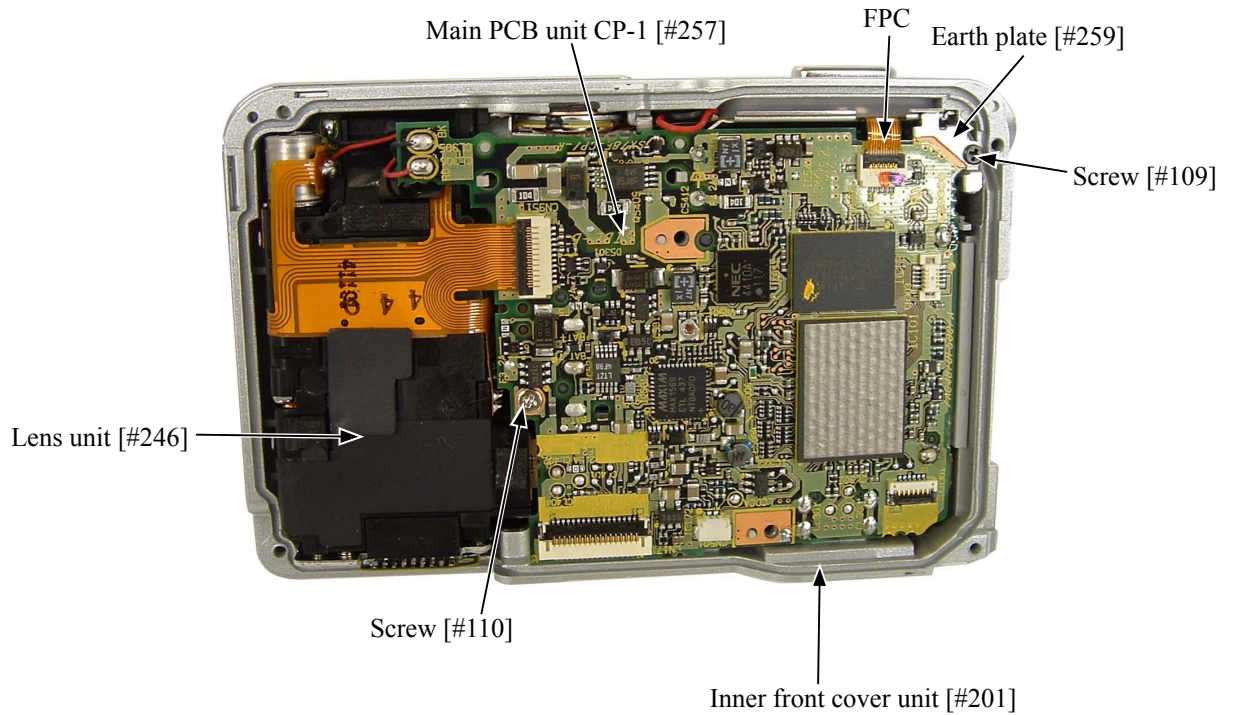

MONITOR HOLDER

- Adhere the shield tape [#261] along the adhering reference position.

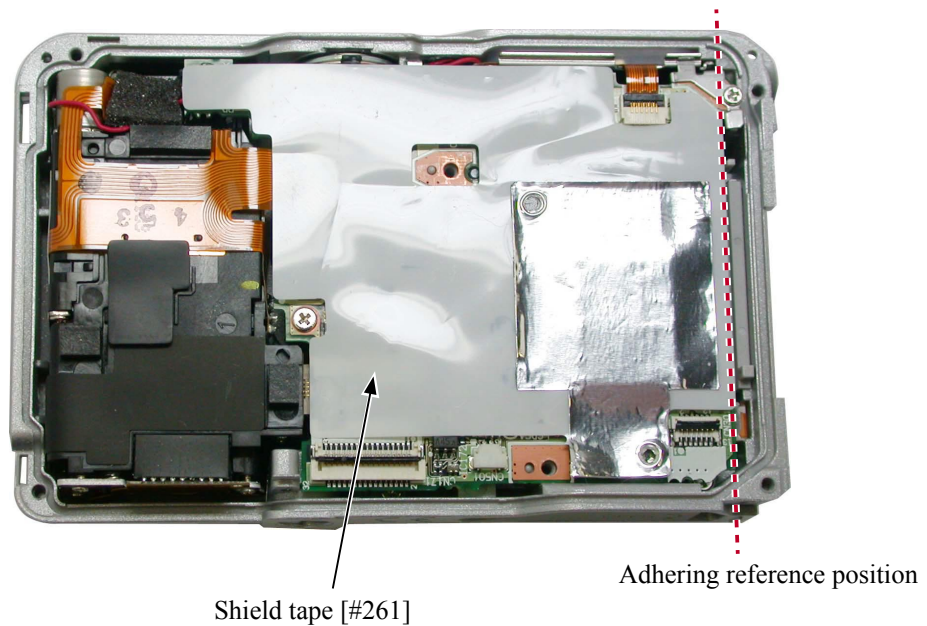

Note: The O-ring [#048] cannot be reused. Replace it with a new one.

The tightening torque value is set for the screw [#105]. Tighten the screw according to the set torque value. (The tightening torque affects the waterproof function.)

- Mount the monitor holder [#263].
- Set the O-rings [#048] onto the screws [#105]. Then, attach the two screws [#105].

<Tightening torque>

	When assembling newly	When reassembling
Screw [#105]	12cN · m	9cN · m

Note:

In case the part, which is attached with the screw and O-ring, is replaced, tighten the screw and O-ring by the torque for assembling.

In the other cases, tighten them by the torque for reassembling.

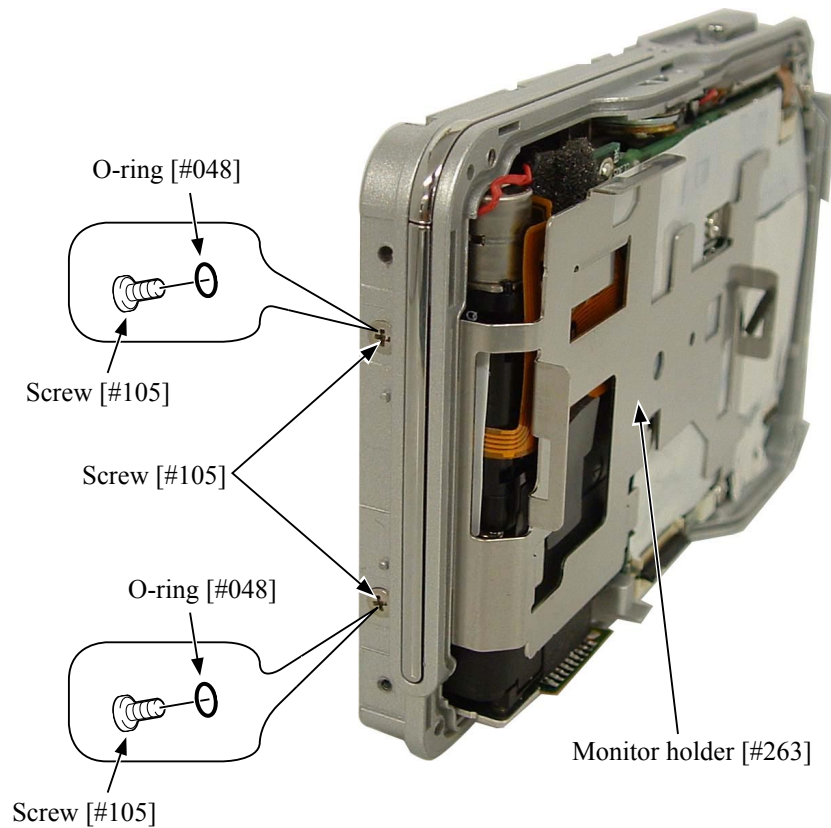

- Mount the spacer [#262].
- Attach the two screws [#110].

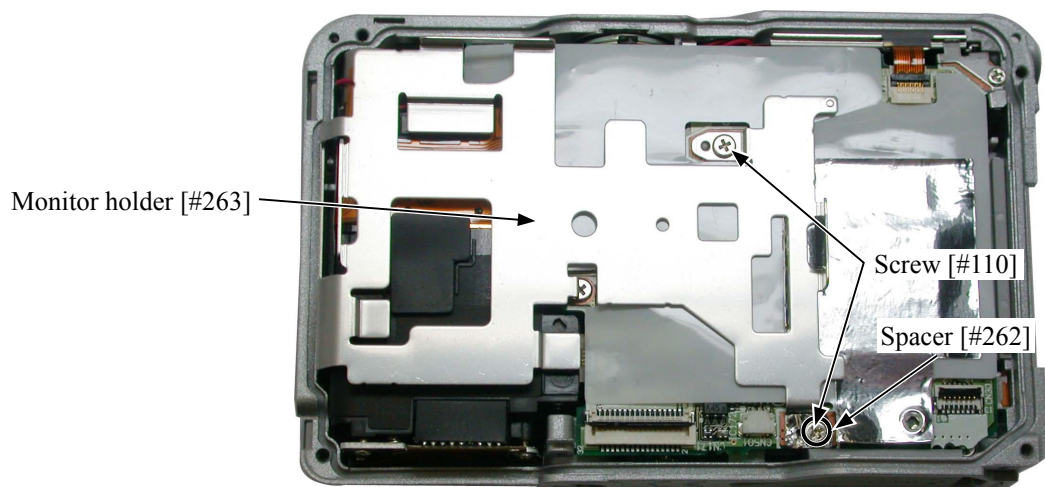

LCD

- Mount the FPC.
- Mount the connector.

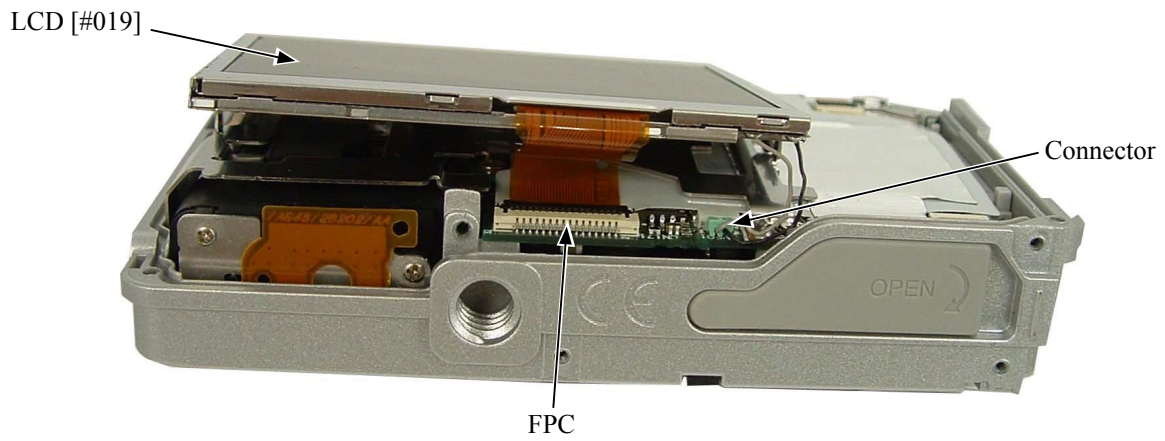

- Mount the LCD [#019] by hooking.
- Arrange the connector's cords as shown below.

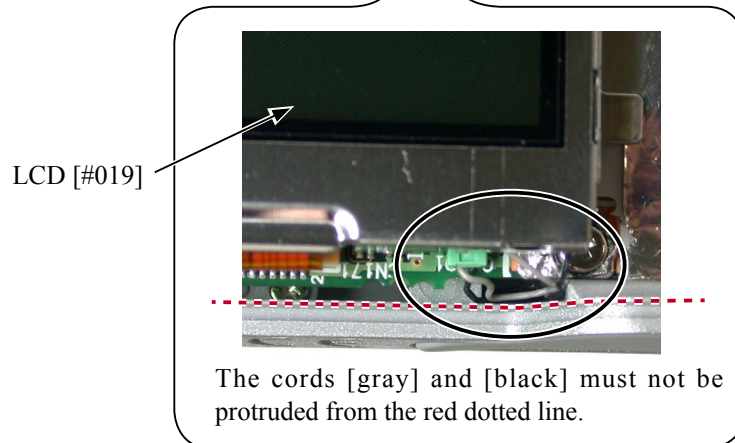
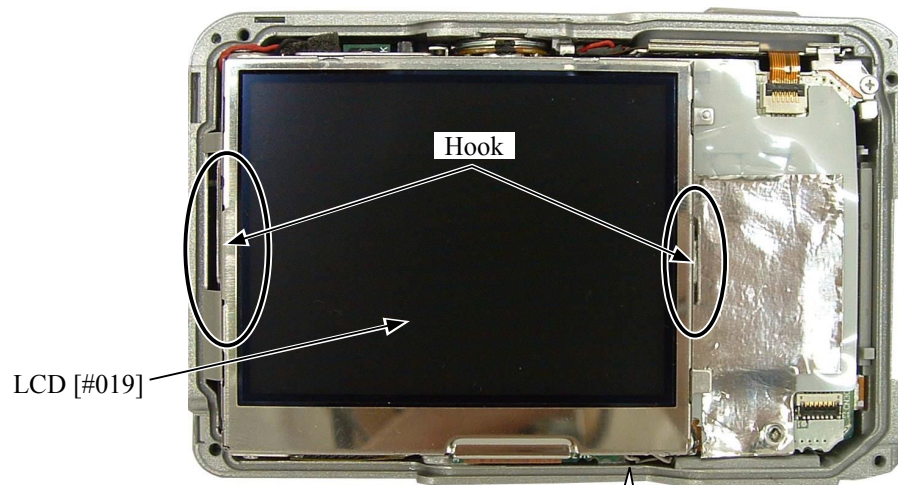

CABINET O-RING

Note: The cabinet O-ring cannot be reused. After removing the cabinet O-ring, replace it with a new one.

Do not use the sharp-pointed tweezers.

Be careful to prevent the cabinet O-ring from dust or fluff. (Dust or fluff affects the waterproof function.)

- Mount the cabinet O-ring [#047] in the order of "A" and "B". Then, adjust its extra part in the range of "C".

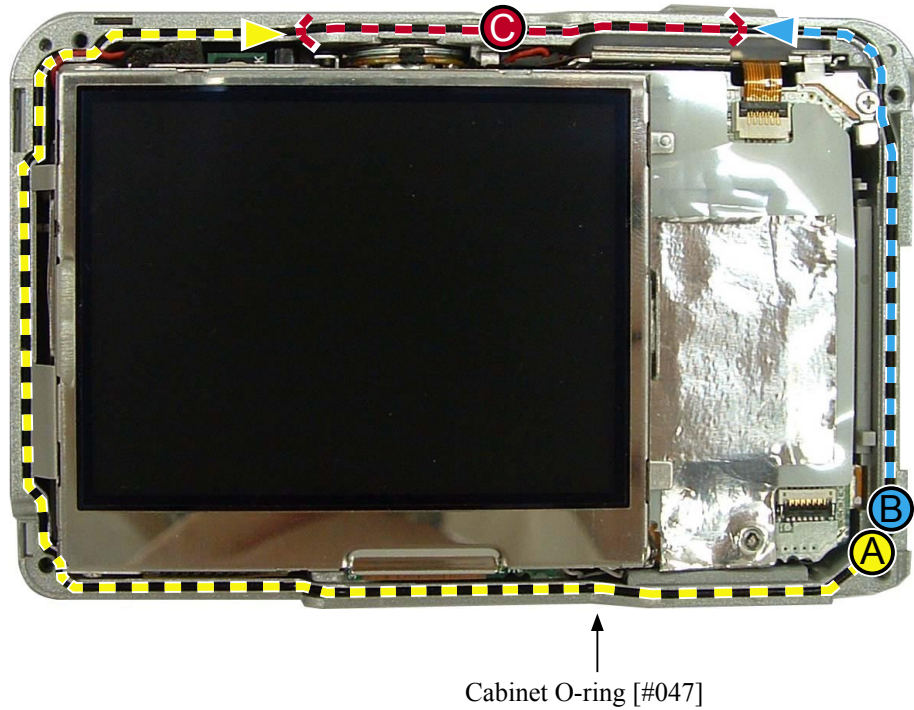

INNER REAR COVER UNIT

- Mount the FPC.
- Mount the inner rear cover unit [#020] by fitting to the bosses.

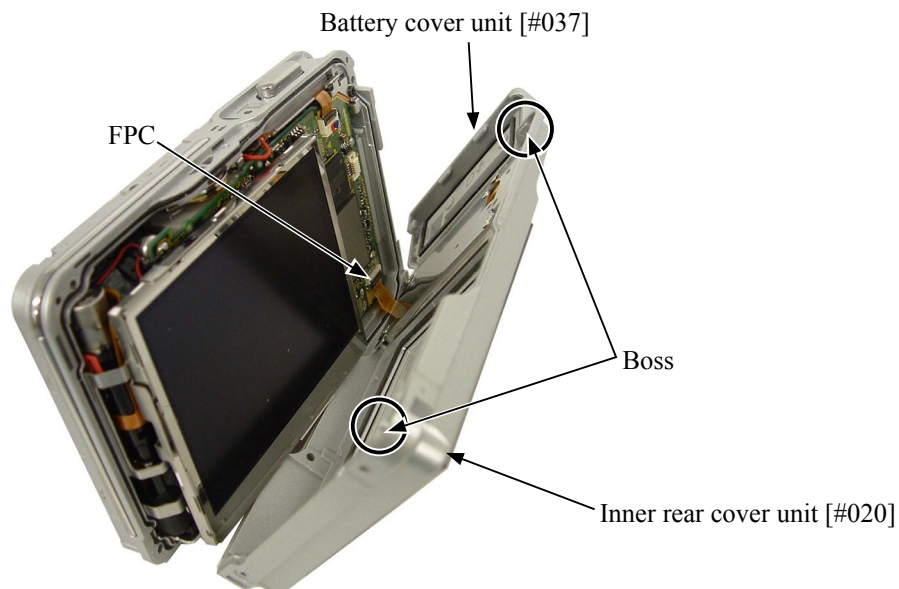

- Tighten the two screws [#104].
- Tighten the two screws [#103].
- Set the O-ring [#048] onto the screw [#105]. Then, tighten the screw [#105].

Note: The tightening torque value is set for the screws [#103], [#104] and [#105]. Tighten the screw according to the set torque value. (The tightening torque affects the waterproof function.)

<Tightening torque>

	When assembling newly	When reassembling
Screw [#103]	12cN · m	9cN · m
Screw [#104]	12cN · m	9cN · m
Screw [#105]	12cN · m	9cN · m

Note:

In case the part, which is attached with the screw and O-ring, is replaced, tighten the screw and O-ring by the torque for assembling.
In the other cases, tighten them by the torque for reassembling.

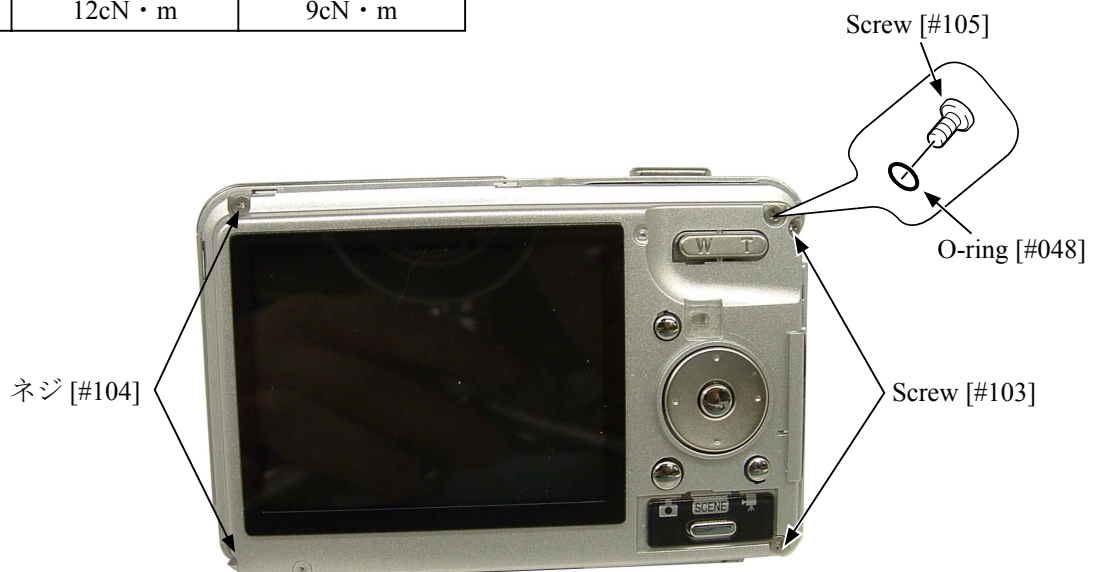

- Set the O-ring [#048] onto the screw [#103]. Then, tighten the screw [#103].

Note: The tightening torque value is set for the screw [#103]. Tighten the screw according to the set torque value. (The tightening torque affects the waterproof function.)

<Tightening torque>

	When assembling newly	When reassembling
Screw [#103]	12cN · m	9cN · m

Note:

In case the part, which is attached with the screw and O-ring, is replaced, tighten the screw and O-ring by the torque for assembling.

In the other cases, tighten them by the torque for reassembling.

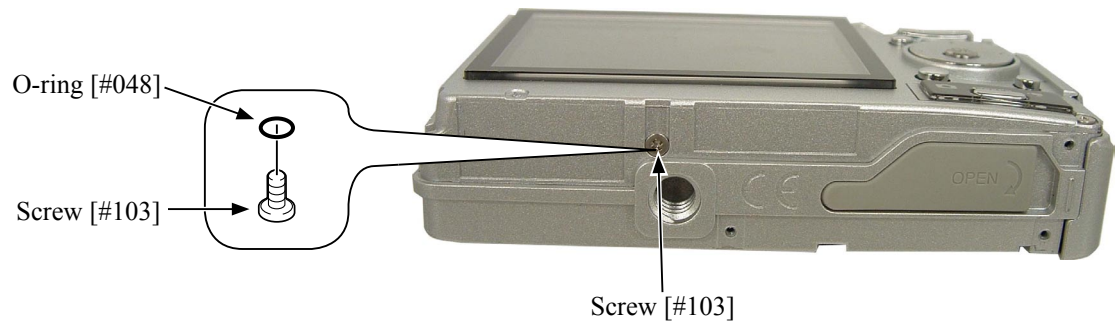

INSTALLATION OF BAND

- Mount the joint top holder [#232] by fitting to the bosses (2 places).
- Mount the joint holder [#231] by fitting to the bosses (2 places).

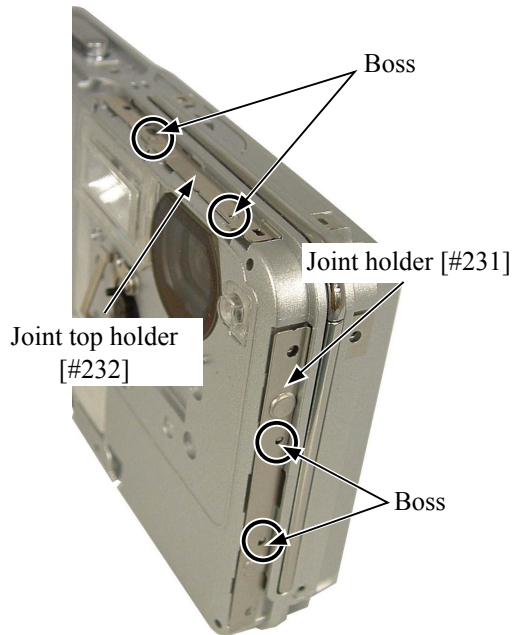

- Mount the power LED window [#235].



- Adhere the double-adhesive tapes [#236] and [#237] to the button ornament [#238] according to the adhering reference position.
- Mount the button ornament [#238].

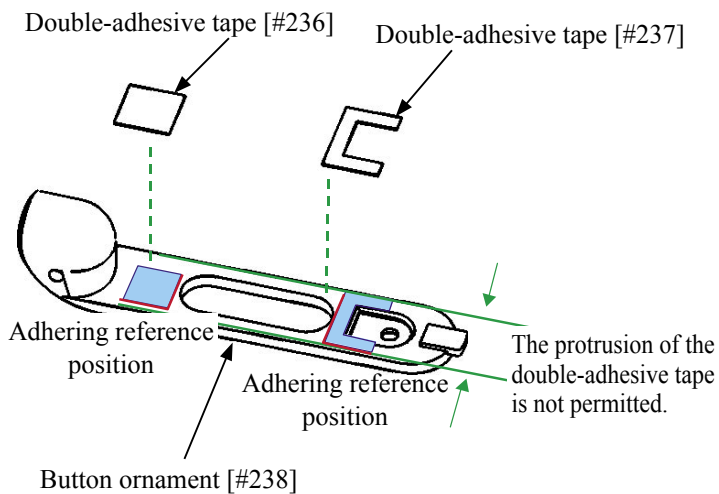

- Mount the shaft strap [#016].



APPLICATION OF GREASE FG-50W

- Apply FG-50W to the spring click.

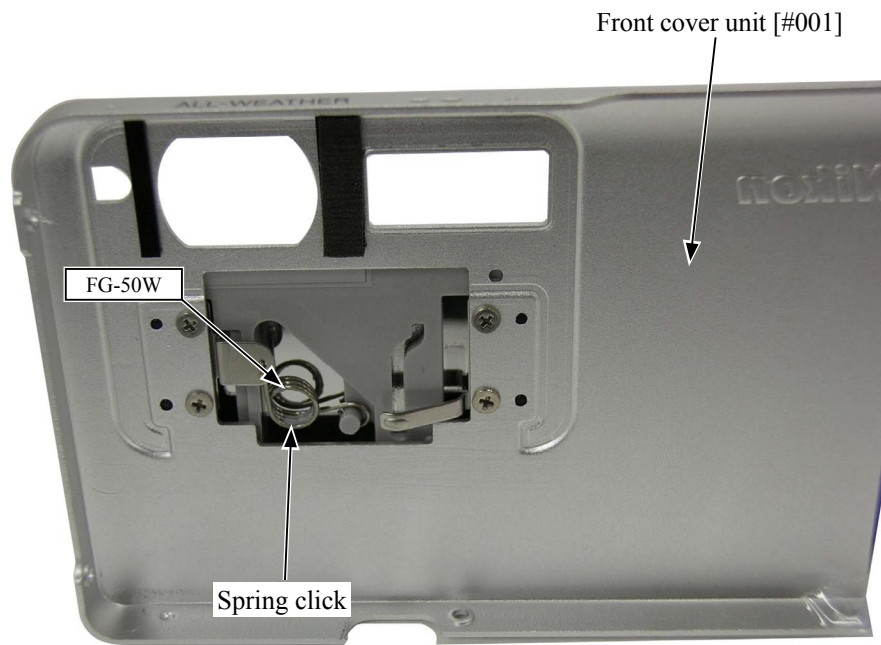

REAR COVER • FRONT COVER UNIT

- Mount the rear cover [#046] and perform hooking at 2 places.

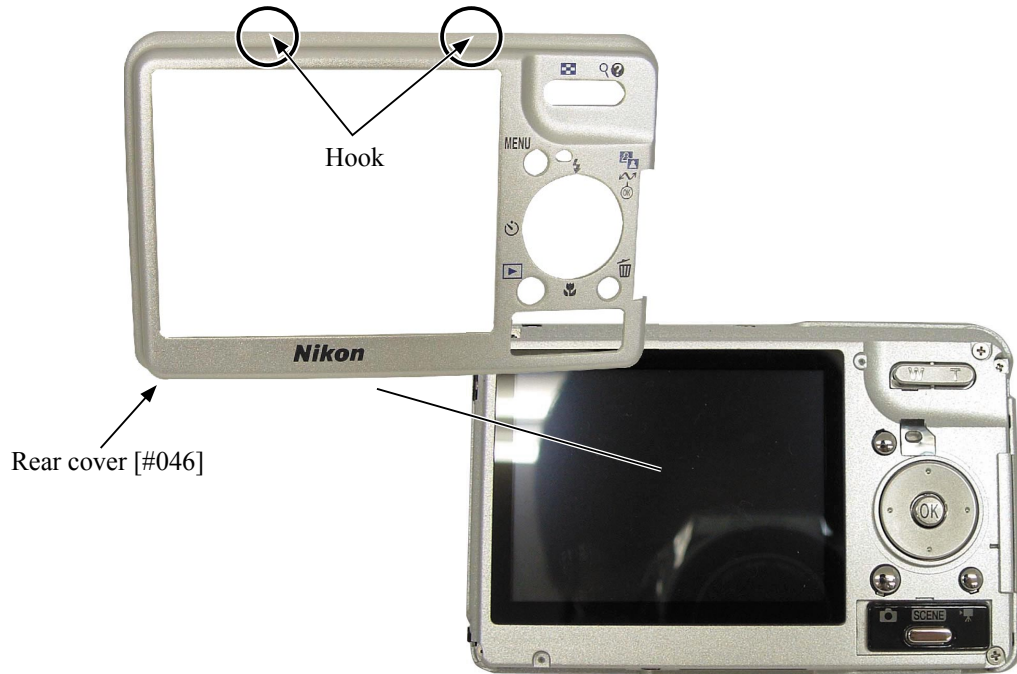

- Set the sensor lever [#207] as shown below and then mount the front cover unit [#001].

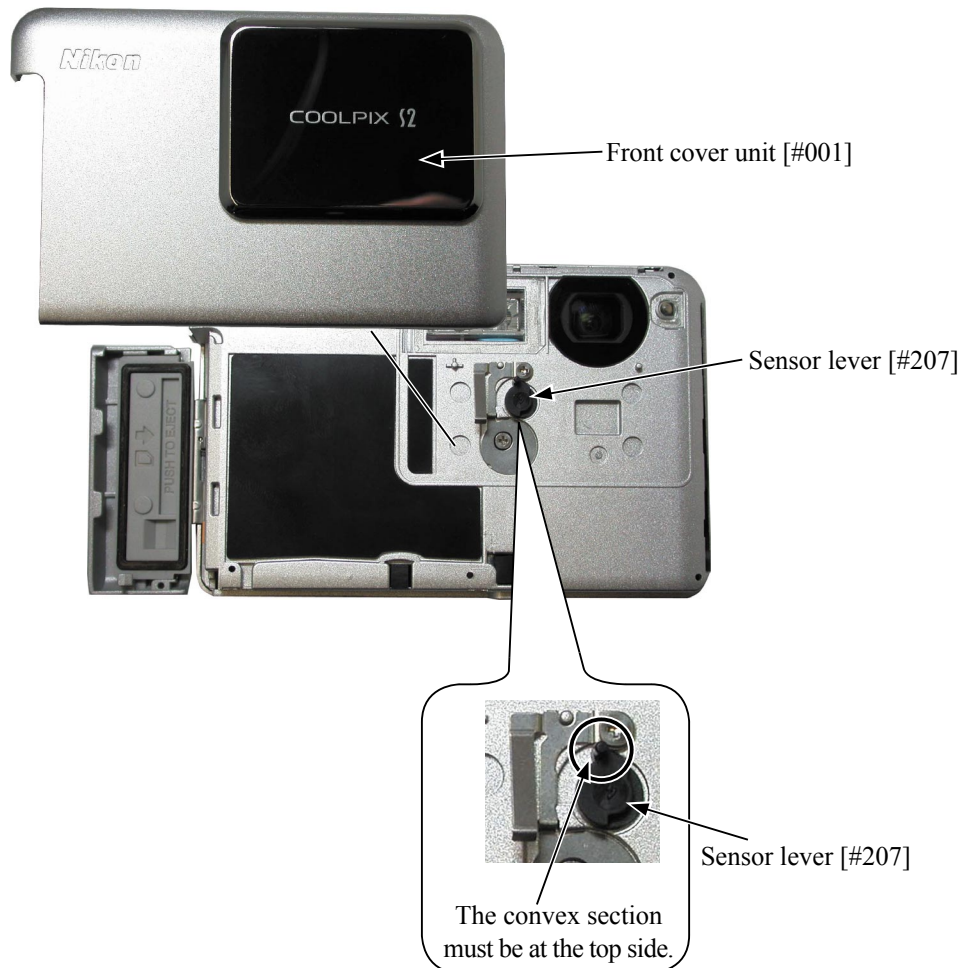

- Tighten the two screws [#101].



- Tighten the three screws [#101].

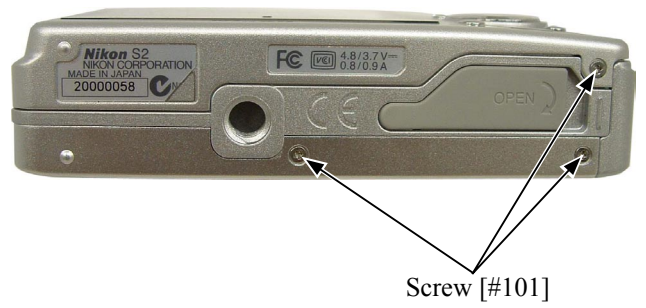

- Tighten the four screws [#101].



AIR LEAK TEST

1. Device:

Camera body, air leak tester, air-leak-tester attachment (with pad), air-leak-tester cradle cover, stopwatch

2. Service tool:



Air leak tester (J15419)

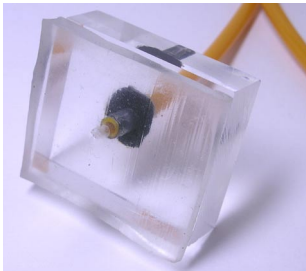

Air-leak-tester attachment (with pad) (J15419-1)



Air-leak-tester cradle cover (J15419-2)

3. Inspection item / order

After assembling the camera body, make an inspection of air leakage as below.

1. Remove the multi-connector terminal cover (cradle cover) at the bottom of the camera body.
2. Set Air-leak-tester attachment and Cradle cover to Tester. (ref. Fig.1)
3. Attach Tester to Camera. (ref. Fig.2)
4. Air leak test

Note) Follow the order from 1 to 4 .

4. Set Air-leak-tester attachment and Cradle cover to Tester

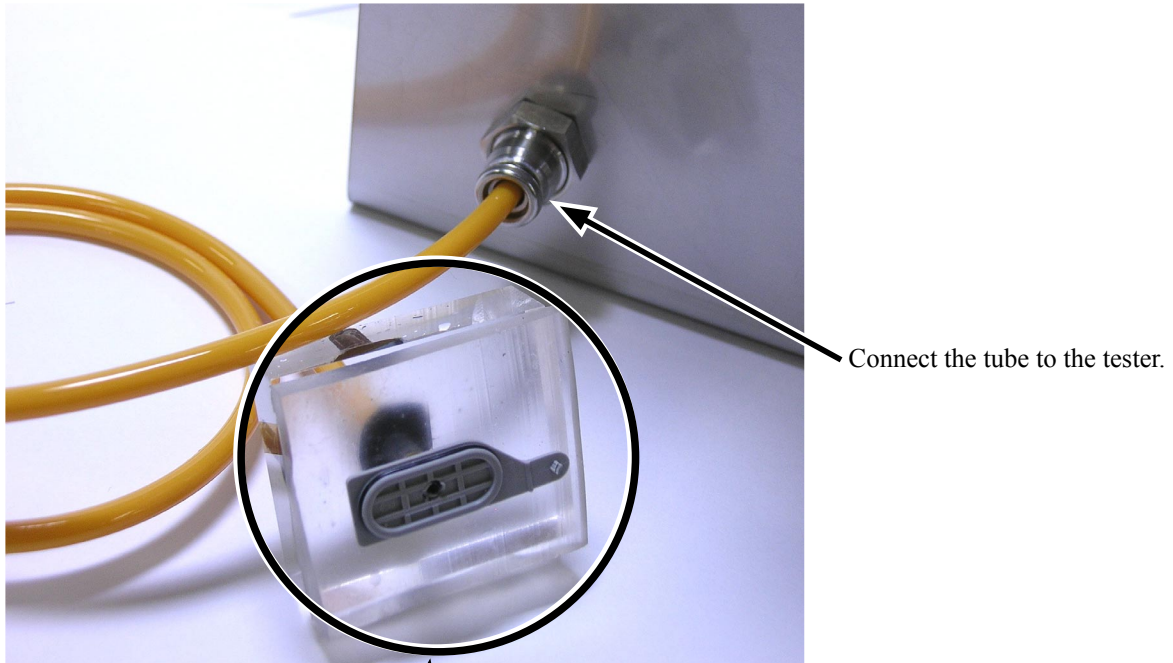
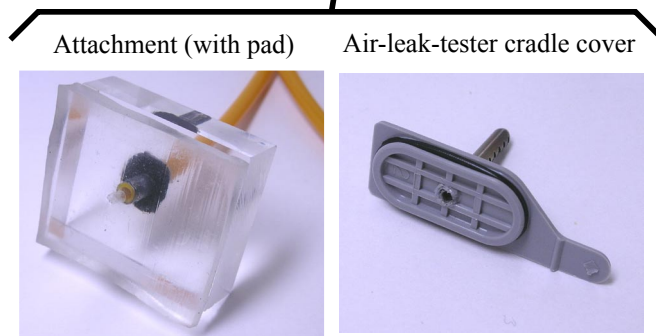

Fig1



5. Attach Tester to Camera

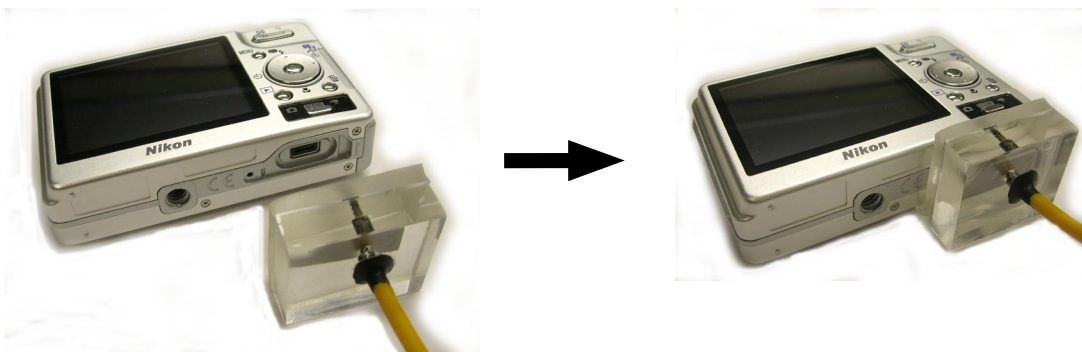

Fig2

5-1 Place the attachment to the multi-connector terminal at the bottom.

Note)

Confirm that there is NO DIRT/DUST on the attachment pad and cradle cover.

5-2 After placing the attachment, fix them with rubber band, etc.

Note)

- Confirm there is **NO** misalignment between the multi-connector terminal and cradle cover.
- Confirm that the SD card/battery cover is surely closed.

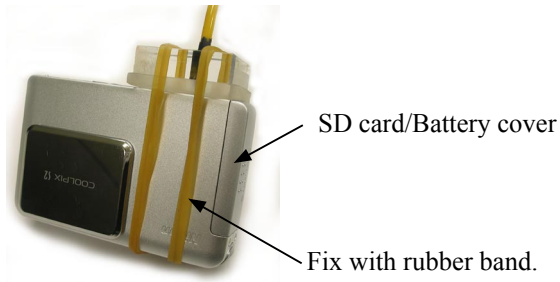

6. Air leak test

6-1 Pull the cylinder knob of the tester, and reduce the pressure to approx. "15kPa(15 kilopascal)".

Note)

- Pull the cylinder knob at a constant speed, with the valve being OPEN.
- Do NEVER let the tester's hand indicator go beyond 20kPa.

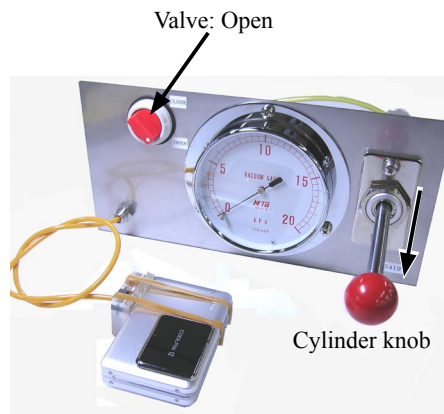

6-2 Close the valve immediately.

- Do not pull/push the cylinder knob, with the valve being CLOSE.

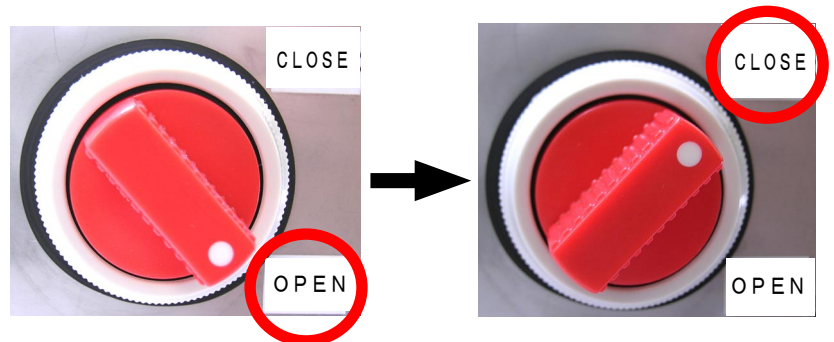

6-3 When the tester's indicator to "10kPa", start the measurement. Make several measurements of the leaking time, which is taken until pointing to "0" position. Then, calculate the average time of them.

Standard: 6 or more sec. on average

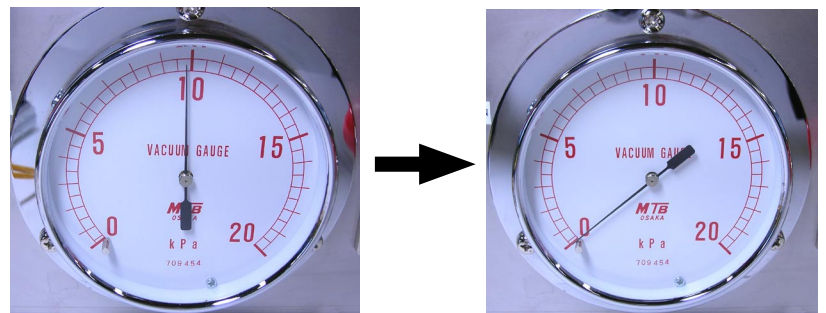

6-4 Remove the camera from the tester, open the valve, and push in the cylinder knob lastly.

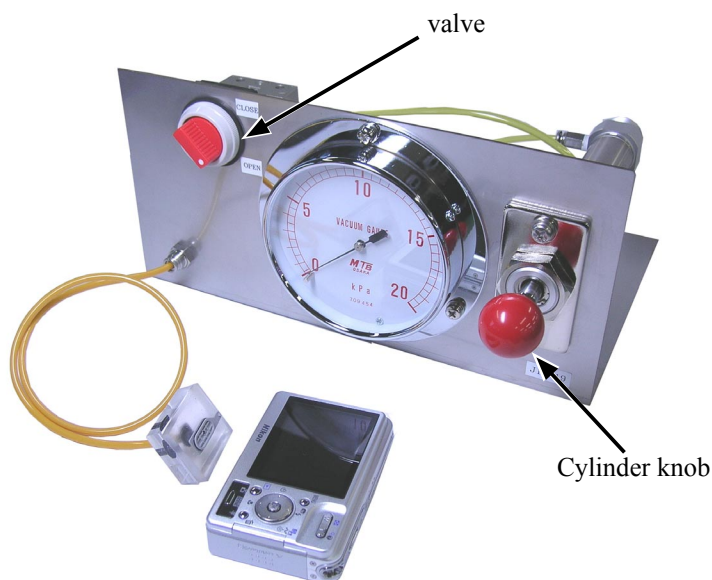

7. In case the inspected air-leaking time is out of standard

- If the air-leaking time is **less than 6 seconds**, the following defects should be considered.

- ① When the camera was assembled, there were defects in O-ring caused by being pinched, twisted, etc.
- ② There were dirt/dust or defects of the air-leak-tester attachment (with pad)/cradle cover.
- ③ There were defective connection between the tester and tube.
- ④ SD card/battery cover was not closed completely, or there were defective parts.

- Measure

- ① It is desirable to disassemble the whole again and reassemble it. **(Confirm that O-ring is tightened by a proper torque. Once O-ring is used, it cannot be reused because it affects drip-proof performance. ref. Page A11 and A13 for details.)**
- ② Clean up dust/dirt, or replace the attachment (with pad)/cradle cover.
- ③ Check the connection between the tester and tube.
- ④ Check that SD card/battery cover is surely closed or replace the parts.

ADJUSTMENT

1. Equipment

IBM compatible PC/AT • AC adapter EH-63 • USB cable (UC-E10) • Cradle (COOL-STATION MV12)

2. Servicing tools

• Pattern box • Color meter • Luminance meter • Calibration software (J65078)
• Adjustment collimator (J63090)

3. Adjustment items and order

Adjustment after replacing the CP-1 PCB of RP

1. Writing of the initial image data
2. Firmware up
3. Lens adjustment
4. AWB adjustment
5. CCD white dot defect compensation
6. CCD black dot/white dot defect adjustment
7. USB storage information registration

Note) The adjustments of the items 3 ~ 7 must be performed again when replacing the lens unit with a new one.

Perform the adjustments of 3 ~ 7 in order.

4. Initial image data writing and Firmware upgrading

Write the data of initial images, and go on to upgrade the firmware.

Device

- AC adapter (EH-63)
- SD card for firmware upgrading (capacity of approx. 16MB) × 1

[How to create an upgrading SD card]

- 1) Format SD card on PC.
- 2) Create a folder named "firmware" in the root directory of the SD card.
- 3) Copy "firmware.bin" into the created folder.
- 4) Copy "nanddat.bin" into the root directory of the same SD card.

Note) When only firmware upgrading is performed without replacing CP-1 PCB, copying "nanddat.bin" into the SD card is not necessary (because the initial image data is included in the CP-1 PCB).

[How to write]

1. Insert the prepared card into the camera.
2. While pressing the central OK button of the multi-selector, press the Playback button for about 1 second.
3. The screen for updates appears. Select "Yes".
4. The message of completing writing appears.

①



Insert the above card (including the data for writing "nanddat" and "Firmware").

③

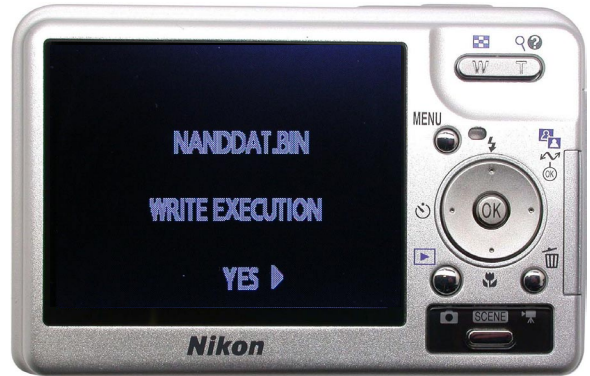

The screen for updates (nanddat) appears. Select "Yes" .

②



Playback button Pressing the central OK button

While pressing the central OK button of the multi-selector, press the playback button for about 1 second.

④



On the previous screen, "nanddat (initial image data)" is written. Then, the screen will change for writing of the product firmware.

⑤



Select "Yes".

⑦



When the message showing the finish of rewriting is displayed, press the reproduction button. The power of the camera is OFF.

⑥



⑧



Turn camera to OFF, then again to ON.
Check the firmware version.

5. Setup of calibration software

1) System requirements

- Windows® 98 or Me, 2000, XP
- IBM-compatible PC/AT with Pentium or higher processor
- CD-ROM drive
- 3.5-inch 2HD diskette drive
- USB port
- 40 MB or more RAM
- Hard disk drive with 15 MB or more memory space
- VGA or SVGA monitor with 256 or more color display

2) Installing calibration software

- Insert the calibration software installation diskette into the diskette drive.
- Open Explorer.
- Copy "DscCalDi.exe, Camapi32.dll" folder of the floppy disk drive in any folder on the hard disk.

6. Installing USB driver

If the USB driver is necessary, install via CD-ROM packed with the camera.

7. Pattern box

Before using the pattern box, turn its power on to carry out "Aging" approx. 30 minutes: the color temperature should be $3100 \pm 20\text{K}$ by the adjustment with the color meter, and the luminance should be $900 \pm 20\text{cd/m}^2$ by the adjustment with the luminance meter. When using the pattern box and for a while after its power turns off, the lamp and its surroundings are subject to high temperatures, so care should be taken when handling.

• Procedure for correcting Pattern Box

Note: Be sure to perform the aging correction.

- 1) Measure the measuring point (center of diffusion plate) with the Color Meter (J63081).
- 2) Adjust the pattern box so that the color temperature should be $3100 \pm 20\text{K}$ by using "VR for adjustment of the color temperature".
- 3) Measure the center of the diffusion plate with the Luminance Meter BM-3000 (J63068).
- 4) Adjust the pattern box so that the luminance should be $900 \pm 20\text{cd/m}^2$ by using "Knob for luminance adjustment".
- 5) Repeat from 1) to 4) So that the color temperature should be $3100 \pm 20\text{K}$ and luminance should be $900 \pm 20\text{cd/m}^2$

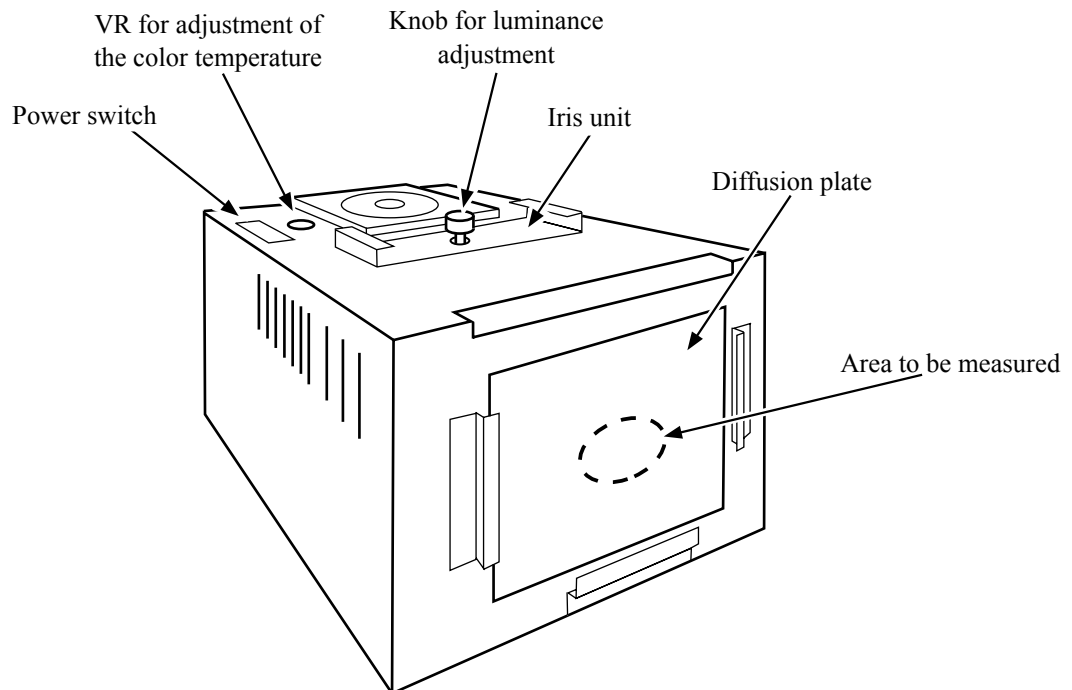

8. Adjustments required when parts are replaced

	Lens Adj.	AWB	CCD white dot	CCD black dot/white dot	USB	Firmware up	Initial image data
Lens Unit	○	○	○	○	×	×	×
CP-1 PCB	○	○	○	○	○	○	○
TB-1 PCB	×	×	×	×	×	×	×
Flash unit	×	×	×	×	×	×	×
LCD	×	×	×	×	×	×	×

○ Adjustment is necessary. × Adjustment is not necessary.

9. Connecting the camera to the computer

- 1) Connect the camera to the cradle.
- 2) Insert the camera connector of the USB cable into the USB port connector of the cradle.
- 3) Connect the cable to the USB port on PC.

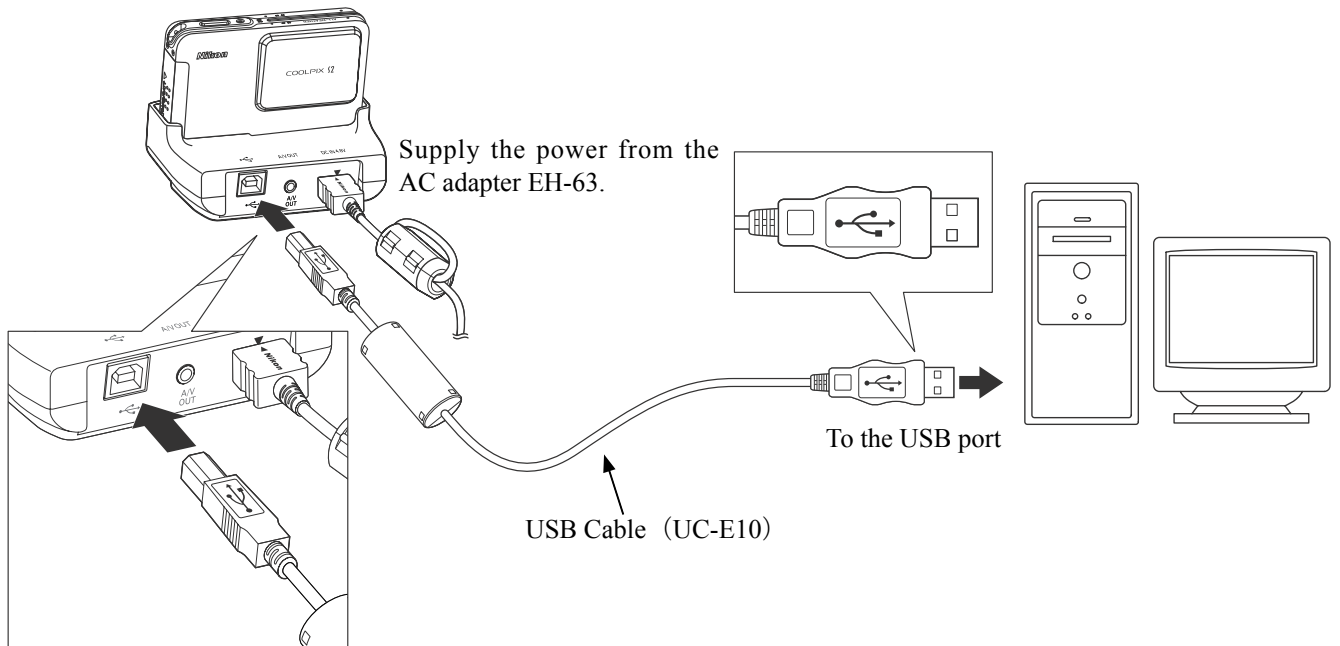

10. Calibration software

- Turn on the power switch of the camera.
- When the calibration software starts, the following is displayed on the PC monitor.

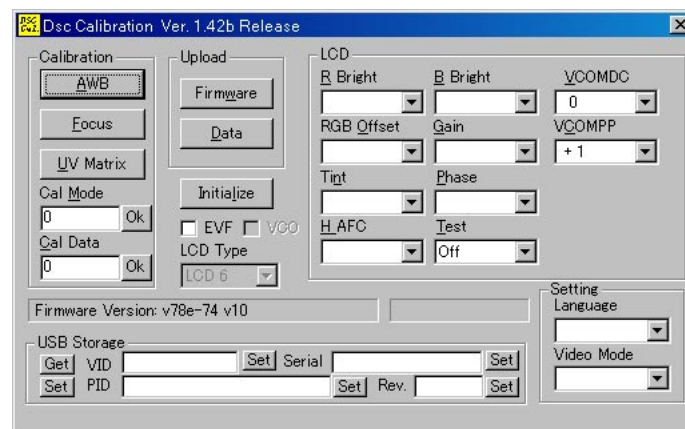

11. Lens adjustment

[Preparations]

- Turn the power switch of the adjustment collimator (C-DSC) J63090 to on.
- Turn the power switch of the camera to on. (Do not connect the USB cable to PC at this time.)
- Check the positions so that the chart center in the collimator may be at the center of the screen.
- Turn the power switch of the camera to off.

[Conditions]

- Set the adjustment collimator and the camera (front surface of lens) so that the distance between them may be as short as possible (approx. 5.5cm).
- When setting the camera onto the cradle, the camera must face the front of the collimator. Set them properly.
- ※ Place the cradle to be horizontal (by using a mount or box properly). (Fig. 1)

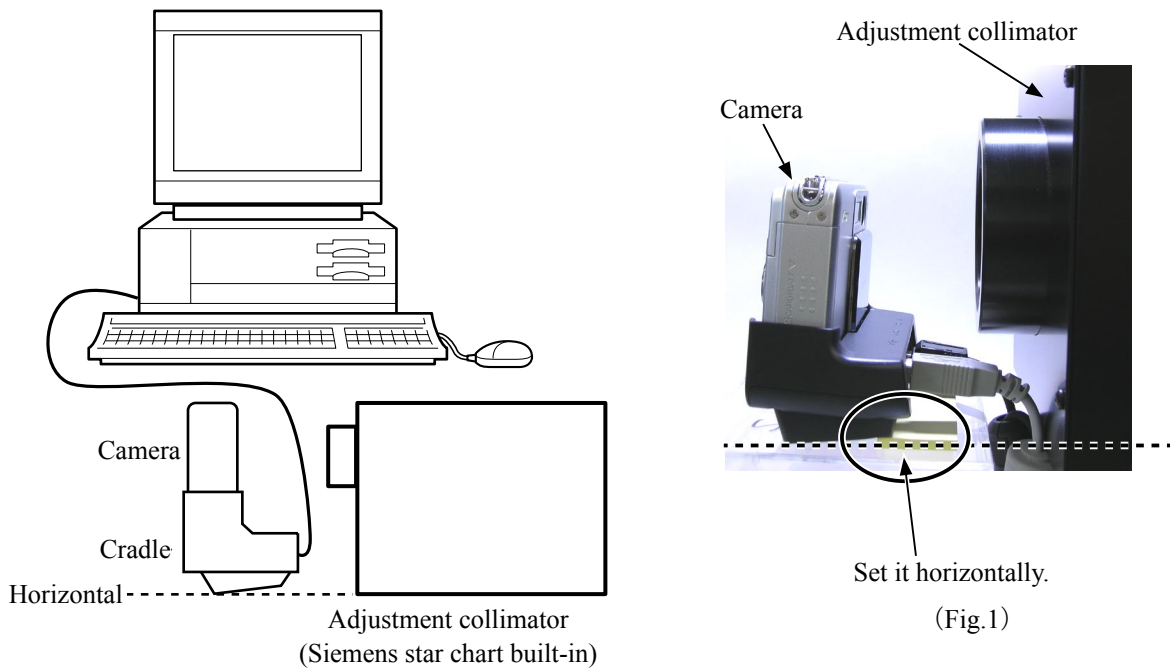

[How to]

- Double-click on "DscCa1Di.exe".
- Select "Lens Data" on "Test" of "LCD".
- Input the value of the bar code, which is attached to the rear of the lens, into the text box of "Lens data Dialog". Then, click "Set". ※ Refer to page A1.
- Click "Exit" and close the dialog box.

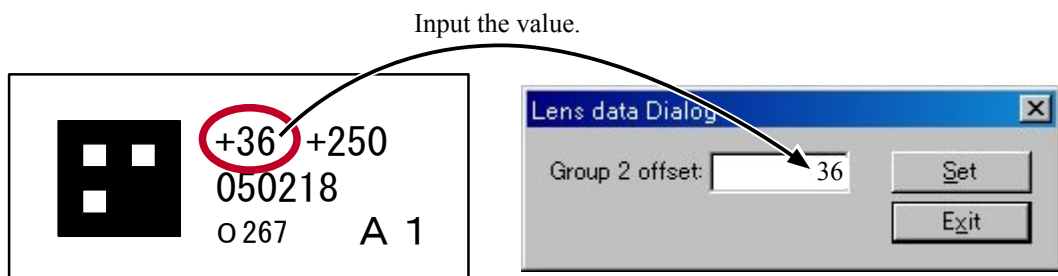

- Click "Focus", then "Yes".

- Lens adjustment value will appear on the screen.

Judgment standard: $xd00 = \pm 55$, $xd01 = \pm 55$, $xd02 = \pm 55$, $xd03 = \pm 55$, $xd04 = \pm 55$, $xd05 = \pm 55$,
 $xd06 = \pm 55$

- Click "OK".

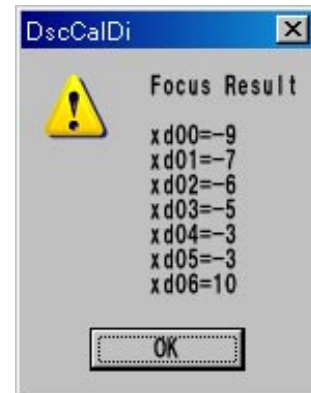
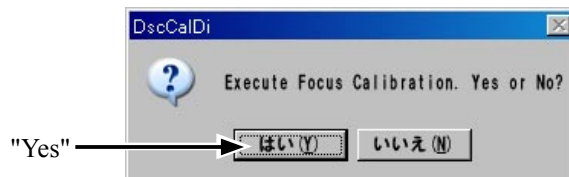

Result of adjustment

12. AWB adjustment

[Preparations]

- Pattern Box (Color temperature: 3100 ± 20K, Luminance: 900 ± 20cd/m²)

[Conditions]

- Set the pattern box and camera (lens front) at "approx 7cm" distance between them.

※ Set the camera and the viewer surface of pattern box to be perpendicular.

Note) Do not allow outside light to enter in. (Use a blackout curtain.)

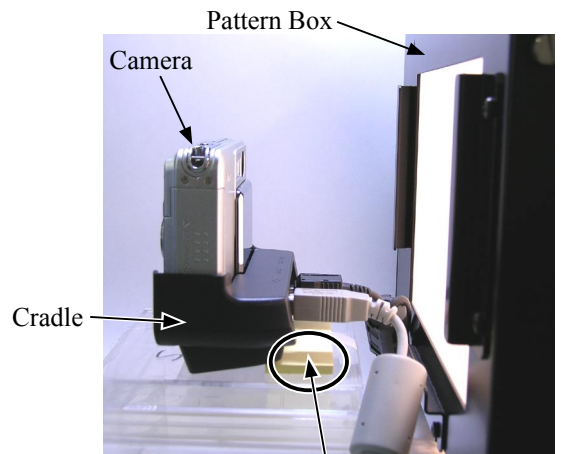
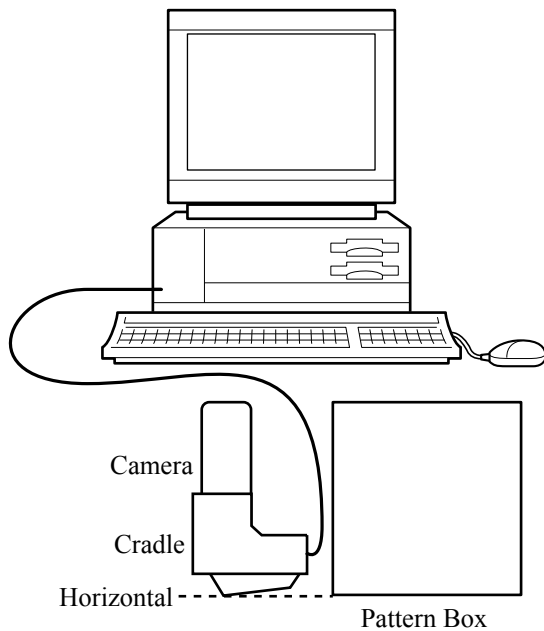

Raise the bottom of the USE terminal side of the cradle by approx 4mm.

[How to]

- Double-click on "DscCalDi.exe".
- Click "AWB", then "Yes".
- AWB adjustment values will appear on the screen.

Judgment standard: CHECK=128 ± 2, 128 ± 2, 130 ± 40

- Click "OK".

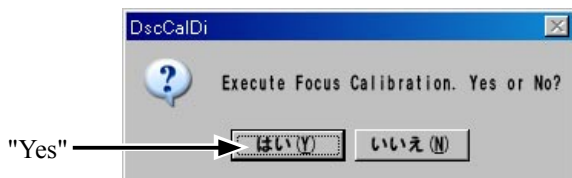

Result of adjustment

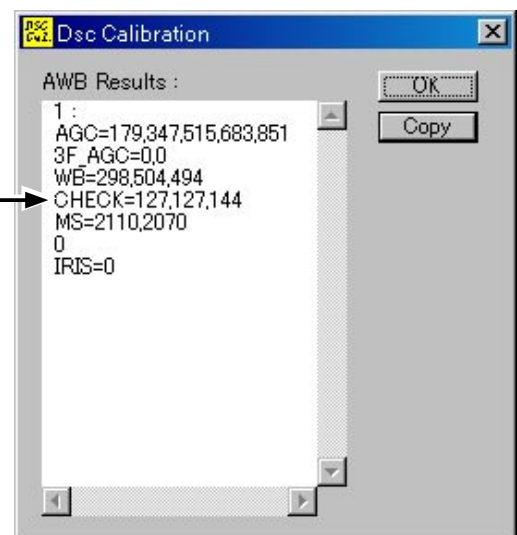

13. CCD white dot defect compensation

[Conditions]

- With the lens shutter being closed, read the defect of CCD pixels. Then, make the correction data and rewrite the data by the following procedure.

Correct the upper level of defective 2000 pixels from the brightest number of CCD pixels..

[How to]

- Double-click on "DscCalDi.exe".
- Select "CCD Defect" from Test menu of Calibration Software and click the "OK". Refer to <FIG-1>.
- After adjustment, the adjustment value will appear on the screen. Refer to <FIG-2>.

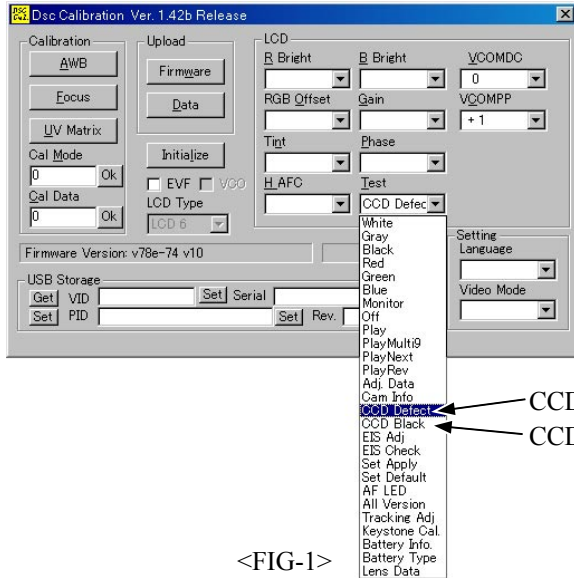

<FIG-1>

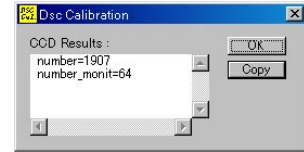

<FIG-2>

14. CCD black dot/white dot defect adjustment

[Conditions]

- Fix the camera so that only the white part of the pattern box should be displayed on the screen.

Note) Do not allow outside light to enter in. (Use a blackout curtain.)

※ Set the camera and the viewer surface of pattern box to be perpendicular.

(Do not allow outside light to enter in as much as possible.)

- With the lens shutter being open, read the defect (black dots) of CCD pixels. Then, make the correction data and rewrite the data by the following procedure.

Correct the upper level of defective 48 pixels (black dots in bright place) of CCD pixels.

[How to]

- Double-click on "DscCalDi.exe".
- Select "CCD Black" from Test menu. Refer to <FIG-1>.
- After adjustment, the adjustment value will appear on the screen. Refer to <FIG-3>.
- Click "OK".

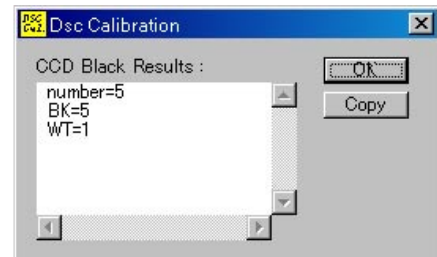
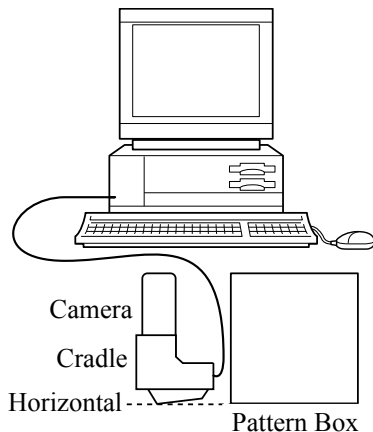

<FIG-3>

15. USB storage information registration

USB storage data is important when the camera is connected to a computer via a USB connection.

If there are any errors in the USB storage data, or if it has not been saved, the USB specifications will not be satisfied, so always check and save the USB storage data.

[How to]

1. Connect the camera to a computer.
2. Double-click on the "DscCalDi.exe".
3. Click on the "Get" button in the USB storage window and check the USB storage data.

VID: NIKON

PID: NIKON DSC S2

Serial:

Rev. : 1.00

4. Check the "Serial" in the above USB storage data. If the displayed value is different from the serial number printed on the base of the camera, enter the number on the base of the camera, and click the "Set" button.
5. Check VID and Rev. entries in the USB storage data. If any of them are different from the values in 3. above, enter the details of 3. and click the "Set" button.

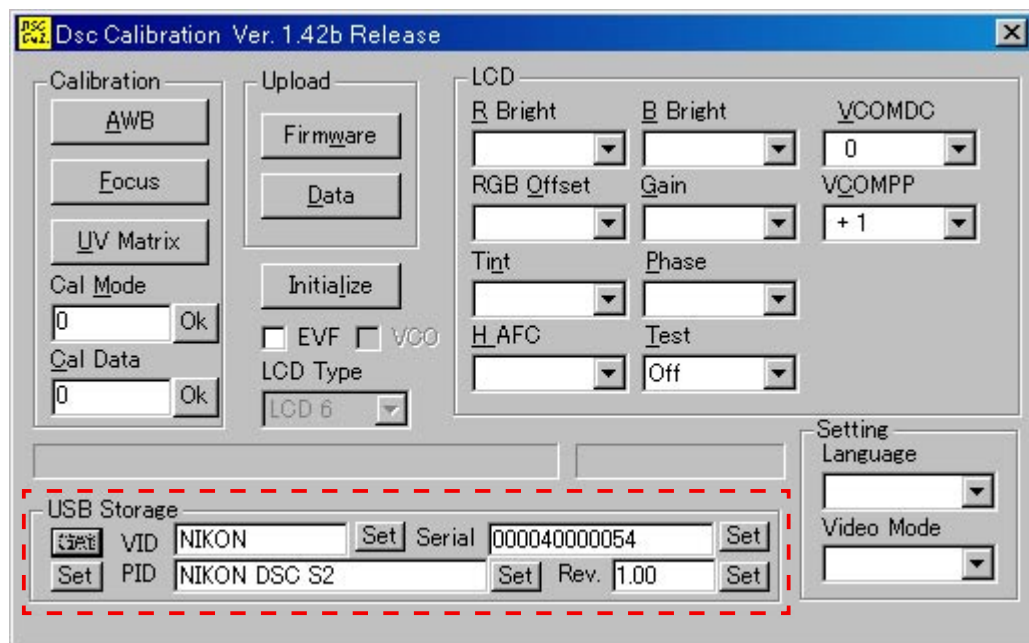

1. OUTLINE OF CIRCUIT DESCRIPTION

1-1. CCD CIRCUIT DESCRIPTION

1. IC Configuration

IC903 (MN39620PJJ)	CCD imager
IC901 (AN20101A)	V driver
IC905 (AD9949KCPZ)	CDS, AGC, A/D converter, H driver

2. IC903 (CCD)

[Structure]

Interline type CCD image sensor

Optical size	1/2.5 type format
Effective pixels	2620 (H) X 1984 (V)
Pixels in total	2690 (H) X 1994 (V)
Optical black	
Horizontal (H) direction:	Front 12 pixels, Rear 58 pixels
Vertical (V) direction:	Front 8 pixels, Rear 2 pixels
Dummy bit number	Horizontal : 28 Vertical : 1

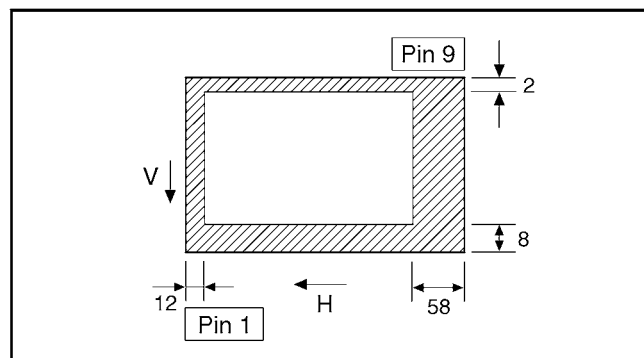

Fig. 1-1. Optical Black Location (Top View)

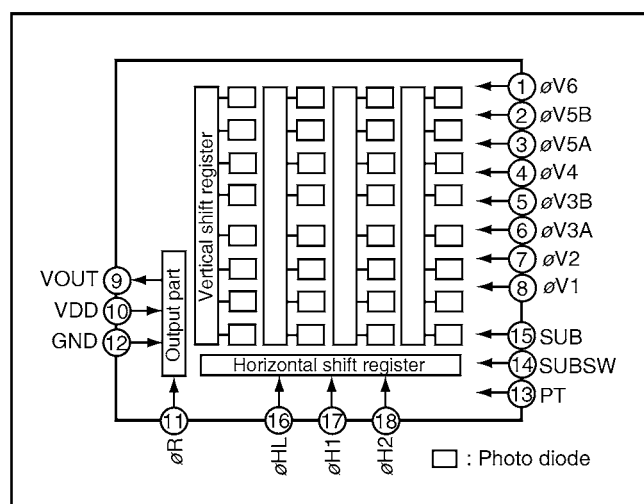

Fig. 1-2. CCD Block Diagram

Pin No.	Symbol	Pin Description	Waveform	Voltage
1	V ₆	Vertical register transfer clock		-6.0 V, 0 V
2, 3	V _{5A} , V _{5B}	Vertical register transfer clock		-6.0 V, 0 V, 12 V
4, 7	V ₂ , V ₄	Vertical register transfer clock		-6.0 V, 0 V
5, 6, 8	V _{3A} , V _{3B} , V ₁	Vertical register transfer clock		-6.0 V, 0 V, 12 V
9	VO	Signal output	DC	Aprox. 12 V
10	OD	Circuit power	DC	12 V
11	ØR	Reset gate clock		4.5 V, 7.8 V
12	PW	GND	GND	0 V
13	PT	Protection transistor bias	DC	-6.0 V
14	SUBC	Substrate control		0, 3.3 V (When importing all picture element: 3.3 V)
15	SUB	Substrate clock	DC	Aprox. 6 V (Different from every CCD)
16, 17	H _L , H ₁	Horizontal register transfer clock		0 V, 3.3 V
18	H ₂	Horizontal register transfer clock		0 V, 3.3 V

Table 1-1. CCD Pin Description

---- When sensor read-out

3. Part of IC905 (H Driver) and IC901 (V Driver)

An H driver (part of IC905) and V driver (IC901) are necessary in order to generate the clocks (vertical transfer clock, horizontal transfer clock and electronic shutter clock) which driver the CCD.

IC905 has the generation of horizontal transfer clock and the function of H driver, and is an inverter IC which drives the horizontal CCDs (H1 and H2). In addition the XV1-XV4 signals which are output from IC101 are vertical transfer clocks, and the XSG signal is superimposed onto XV1 and XV3 at IC901 in order to generate a ternary pulse. In addition, the XSUB signal which is output from IC101 is used as the sweep pulse for the electronic shutter, and the RG signal which is output from IC905 is the reset gate clock.

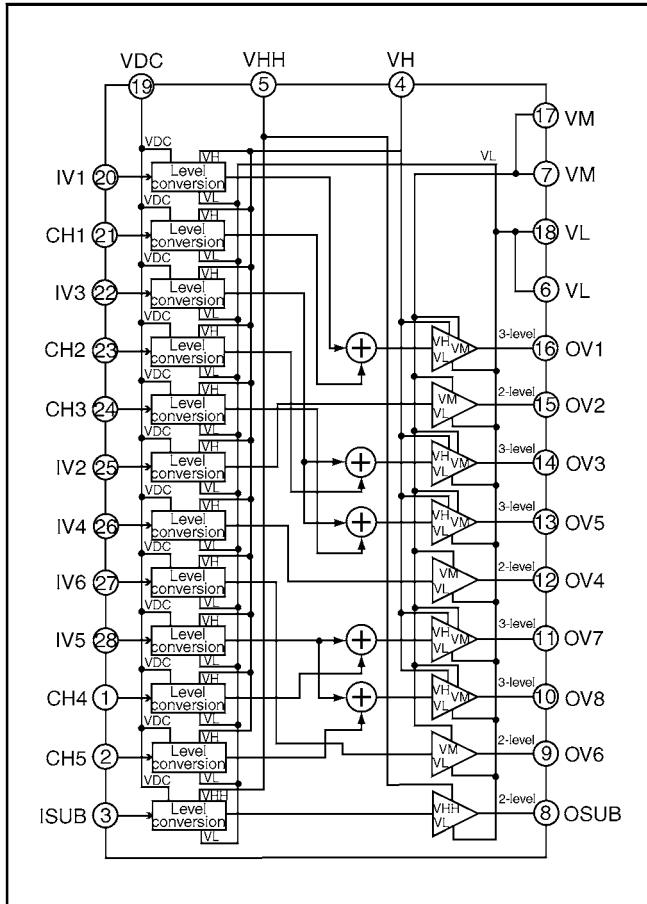

Fig. 1-3. IC901 Block Diagram

4. IC905 (H Driver, CDS, AGC and A/D converter)

IC905 contains the functions of H driver, CDS, AGC and A/D converter. As horizontal clock driver for CCD image sensor, H01 (A and B) and H02 (A and B) are generated inside, and output to CCD.

The video signal which is output from the CCD is input to pins (27) of IC905. There are sampling hold blocks generated from the SHP and SHD pulses, and it is here that CDS (correlated double sampling) is carried out.

After passing through the CDS circuit, the signal passes through the AGC amplifier (VGA: Variable Gain Amplifier). It is A/D converted internally into a 10-bit signal, and is then input to ASIC (IC101). The gain of the VGA amplifier is controlled by pin (31)-(33) serial signal which is output from ASIC (IC101).

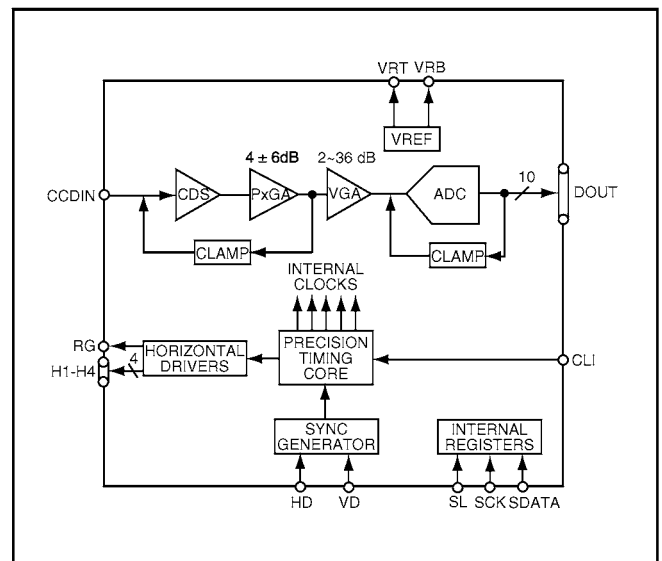

Fig. 1-4. IC905 Block Diagram

1-2. CP1 CIRCUIT DESCRIPTION

1. Circuit Description

1-1. Digital clamp

The optical black section of the CCD extracts averaged values from the subsequent data to make the black level of the CCD output data uniform for each line. The optical black section of the CCD averaged value for each line is taken as the sum of the value for the previous line multiplied by the coefficient k and the value for the current line multiplied by the coefficient $1-k$.

1-2. Signal processor

1. γ correction circuit

This circuit performs (gamma) correction in order to maintain a linear relationship between the light input to the camera and the light output from the picture screen.

2. Color generation circuit

This circuit converts the CCD data into RGB signals.

3. Matrix circuit

This circuit generates the Y signals, R-Y signals and B-Y signals from the RGB signals.

4. Horizontal and vertical aperture circuit

This circuit is used generate the aperture signal.

1-3. AE/AWB and AF computing circuit

The AE/AWB carries out computation based on a 256-segment screen, and the AF carries out computations based on a 11-segment screen.

1-4. SDRAM controller

This circuit outputs address, RAS, CAS, CS and WE data for controlling the SDRAM. It also refreshes the SDRAM.

1-5. Communication control

1. SIO

This is the interface for the 8-bit microprocessor.

2. PIO/PWM/SIO for LCD

8-bit parallel input and output makes it possible to input and output individually, and three ports of them PWM output makes it possible to switch. It is prepared for 16-bit parallel output.

1-6. TG

Timing generated for 5 million pixels CCD control.

1-7. Digital encorder

It generates chroma signal from color difference signal.

1-8. JPEG encorder and decorder

It is compressed and elongated the data by JPEG system.

2. Outline of Operation

When the shutter opens, the reset signals and the serial signals ("take a picture" commands) from the 8-bit microprocessor are input to ASIC (IC101) and operation starts. When the TG/SG drives the CCD, picture data passes through the A/D and CDS, and is then input to the ASIC as 10-bit data. The AF, AE, AWB, shutter, and AGC value are computed from this data, and three exposures are made to obtain the optimum picture. The data which has already been stored in the SDRAM is read by the CPU and color generation is carried out. After AWB and γ processing are carried out by RGB data, a matrix is generated and aperture correction is carried out for the Y signal, and the data is then compressed by the JPEG method by (JPEG) and is then written to card memory (SD card). When the data is to be output to an external device, it is taken data from the memory and output via the USB. When played back on the LCD and monitor, data is transferred from memory to the SDRAM, and the data elongated by JPEG decorder is displayed over the SDRAM display area.

3. LCD Block

The LCD display circuit is located on the CP1 board, and consists of components such as a power circuit.

The signals from the ASIC are 8-bit digital signals, that is input to the LCD directly. The 8-bit digital signals are converted to RGB signals inside the LCD driver circuit. This LCD is input signals from ASIC directly to the LCD, and function such as image quality are controlled.

Because the LCD closes more as the difference in potential between the VCOM (common polar voltage: AC) and the R, G and B signals becomes greater, the display becomes darker; if the difference in potential is smaller, the element opens and the LCD become brighter.

In addition, the timing pulses for signals other than the video signals are also input from the ASIC directory to the LCD.

4. Lens drive block

4-1. Focus drive

The three control signals (FCLK, FCW and FOE) which are output from the ASIC (IC101) are converted into drive pulses (STM3-1A, STM3-2A, STM3-1B and STM3-2B) by the motor driver (IC951), and are then used to drive micro step the stepping motor for focusing operation. Detection of the standard focusing positions is carried out by means of the photointerruptor (PI3-E) inside the lens block.

4-2. Shutter drive

The two control signals (SIN1 and SIN2) which are output from the ASIC (IC101) are converted into drive regular current (SHUTTER (+) and SHUTTER (-)) by the motor driver (IC951), and the shutter is opened and closed.

4-3. Iris drive

The two control signals (IIN1 and IIN2) which are output from the ASIC (IC101) are converted into drive (IRIS (+) and IRIS (-)) by the motor driver (IC951), and are then used to drive the iris steps.

4-4. Zoom drive

The three control signals (ZCLK, ZCW and ZOE) which are output from ASIC (IC101) are converted into drive pulses (STM2-1A, STM2-2A, STM2-1B and STM2-2B) by the motor driver (IC951), and are then used to drive micro step the stepping motor for zoom operation.

Detection of the standard zoom positions is carried out by means of the photointerruptor (PI2-E) inside the lens block.

1-3. PWA POWER CIRCUIT DESCRIPTION

1. Outline

This is the main power circuit, and is comprised of the following blocks.

Switching controller (IC501)

Digital and analog system power output
(L5004, T5001, Q5001, IC522)

Digital 3.25 V power output (L5005)

Digital 1.41 V power output (L5006)

LCD 15 V system power output (L5009, Q5005)

Backlight power output (L5008, Q5003)

Motor system power output (IC531, L5301, Q5301)

2. Switching Controller (IC501)

This is the basic circuit which is necessary for controlling the power supply for a PWM-type switching regulator, and is provided with six built-in channels, only CH_M (digital 3.25 V), CH_SD (digital 1.41 V), CH_SU (digital system), CH1 (analog system), CH2 (LCD system) and CH3 (backlight system) are used. Feedback from 3.25 V (D) (CH_M), 1.41 V (D) (CH_SD), digital system (CH_SU), analog system (CH1), LCD system (CH2) and backlight system (CH3) power supply outputs are received, and the PWM duty is varied so that each one is maintained at the correct voltage setting level.

Feedback for the backlight power (CH3) is provided to the both ends voltage of resistance so that regular current can be controlled to be current that was setting.

2-1. Short-circuit protection circuit

If output is short-circuited for 200 ms, all output is turned off. The control signal (P ON) are recontrolled to restore output.

3. Analog System Power Output

+12.0 V (A), +3.45 V (A) and -6.0 V (A) are output. Feedback for the +12.0 V (A) is provided to the switching controller (Pin (3) of IC501) so that PWM control can be carried out.

4. Digital 3.25 V Power Output

+3.25 V (D) is output. Feedback for the +3.25 V (D) is provided to the switching controller (Pin (13) of IC501) so that PWM control can be carried out.

5. Digital 1.41 V Power Output

+1.41 V (D) is output. Feedback for the +1.41 V (D) is provided to the switching controller (Pin (9) of IC501) so that PWM control to be carried out.

6. Digital System Power Output

+5 V (D) is output. Feedback for the +5 V (D) is provided to the switching controller (Pin (17) of IC501) so that PWM control to be carried out.

7. LCD System Power Output

+15 V (L) and 5 V (L) are output. Feedback for the +15 V (L) is provided to the switching controller (Pin (31) of IC501) so that PWM control can be carried out.

8. Backlight Power Supply output

Regular current (19 mA) is being transmitted to LED for LCD backlight. Feedback for the both ends voltage of resistance that is being positioned to in series LED are provided to the switching controller (Pin (39) of IC501) so that PWM control to be carried out.

9. Motor System Power Output

5.3 V is output. Feedback for the 5.3 V output is sent to pin (1) of IC531 for PWM control to be carried out.

10. Camera charging circuit

If the camera's power is turned off while it is connected to the cradle, the battery will be recharged. In the above condition, a CTL signal is sent from the microprocessor and recharging starts.

1-4. SYA CIRCUIT DESCRIPTION

1. Configuration and Functions

For the overall configuration of the SYA block diagram, refer to the block diagram. The SYA block centers around a 8-bit microprocessor (IC301), and controls camera system condition (mode). The 8-bit microprocessor handles the following functions.

1. Operation key input, 2. Clock control and backup, 3. Power ON/OFF, 4. Strobe charge control.

Pin	Signal	I/O	Outline
1	AVREF	I	Analog standard voltage input terminal
2	AVSS	-	GND
3	IC (FLMD0)	I	Power for program writing
4	VDD	I	VDD
5	REGC	-	Regulator output stability capacity connection
6	VSS	-	GND
7	XIN	I	Main clock oscillation terminal (4MHz)
8	XOUT	O	Main clock oscillation terminal
9	RESET	I	Reset input
10	XCIN	I	Clock oscillation terminal for clock (32.768 kHz)
11	XCOUT	O	Clock oscillation terminal for clock
12	BAT_CHG ON	O	Battery charging control signal
13	BAT_OFF	I	Battery OFF detection signal input
14	SHUTTER 2nd	I	Shutter 2nd key input
15	USB CONNECT	I	USB power detection terminal
16	DC IN	I	DC jack detection
17	SREQ	I	Serial communication request signal
18	BACKUP_CTL	O	Backup battery charging control (L= charging)
19	BEEP	O	Buzzer monophonic rectangular wave output
20	SHUTTER 1st/FLMD1	O	Shutter halfway push input/power for program writing
21	LCD PWM	O	LCD backlight brightness adjustment
22	LCD ON 1	O	D/D converter (LCD system) ON/OFF signal 1
23	LCD ON 2	O	D/D converter (LCD system) ON/OFF signal 2
24	MOVIE LED	O	Movie LED (H= Lighting)
25	SCAN IN 3/PRG SO	I	Keymatrix input/Flash for serial data output
26	SCAN IN 2/PRG SI	I	Keymatrix input/Flash for serial data input
27	SCAN IN 1/PRG SCK	I	Keymatrix input/Flash for serial clock output
28	MAIN RESET	O	System reset (MRST)
29	AV JACK	I	AV jack detection
30	ST LED (R)	O	ST LED (red) (L= Lighting)
31	AF LED (G)	O	AF LED (green) (L= Lighting)
32	VSS	-	GND
33	VDD	I	VDD
34	P ON	O	D/D converter (digital system) ON/OFF signal
35	PA ON	O	D/D converter (analog system) ON/OFF signal
36	SCK	O	Serial clock output
37	SI	I	Serial data input
38	SO	O	Serial data output
39	ST_CHG ON	O	Strobe charging control
40	FLMD0_SY	O	Port for microprocessor card rewriting
41~44	SCAN OUT 3~0	O	Key matrix output
45	PLLEN	O	PLL oscillation ON/OFF
46	ASIC TEST	O	ASIC control signal (ZTEST)

47	BAT CHG ERR	I	Battery charging error detection
48	SW3.2 ON	O	SW3.2 V control signal (L= ON)
49	COMREQ	I	ASIC serial communication request
50	SCENE LED	O	Scene LED (H= lighting)
51	PW_LED	O	PW_LED (H= lighting)
52	TH ON	O	Built-in battery thermistor control (L= ON)
53	PA ON2	O	D/D converter (analog system) ON/OFF signal 2
54	SELF LED	O	Self LED (H= lighting)
55	AUTO LED	O	Auto LED (H= lighting)
56	SCAN IN 0	I	Keymatrix input
57	CARD	I	SD card detection (L= card)
58	TIME OUT	I	Battery charging completion detection
59	BAT_CHG I	I	Charging current detection
60	TEMP LENS	I	Lens temperature detection
61	BAT_TEMP	I	Battery temperature detection
62	BODY_TEMP	I	Camera temperature detection
63	VMONIT	I	Main condensor charging voltage detection
64	BATTERY	I	Battery voltage detection

Table 4-1. 8-bit Microprocessor Port Specification

2. Setting of external port and communication

The SYA block carries out overall control of camera operation by detecting the input from the keyboard and the condition of the camera circuits. The 8-bit microprocessor reads the signals from each sensor element as input data and outputs this data to the camera circuits (ASIC) or to the LCD display device as operation mode setting data. Fig. 4-1 shows the internal communication between the 8-bit microprocessor and ASIC.

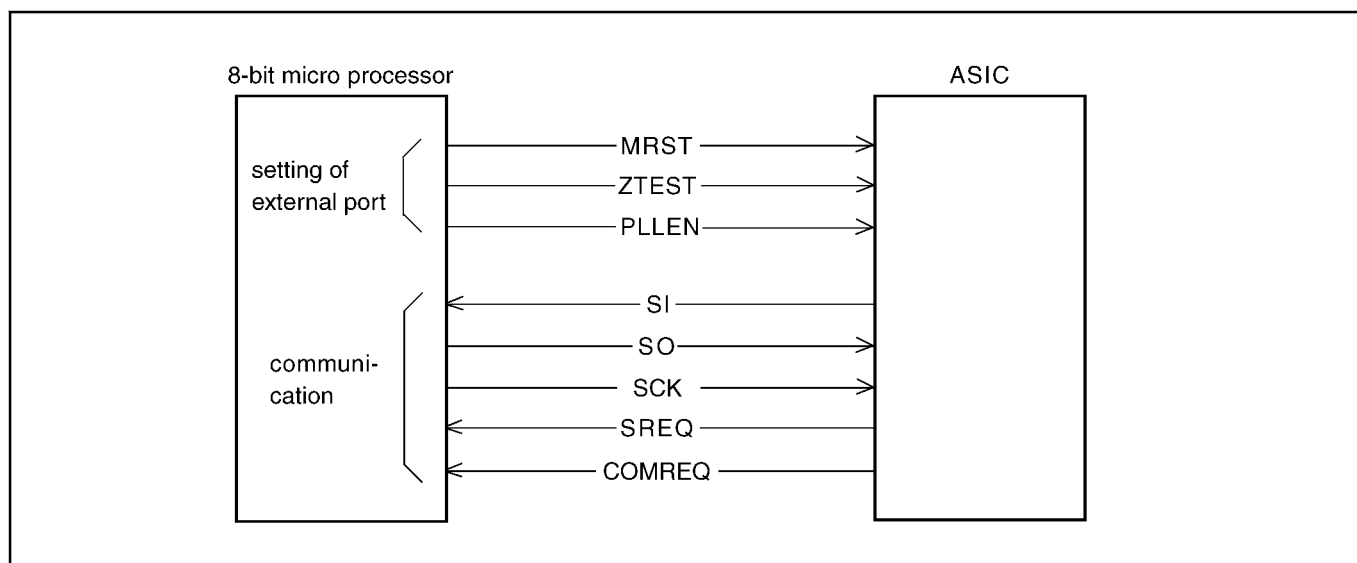

Fig. 4-1 Internal Bus Communication System

3. Key Operaiton

For details of the key operation, refer to the instruction manual.

SCAN OUT \ SCAN IN	0	1	2	3
0	-	-	TEST	PW_TEST
1	PLAY	MODE	DEL	OK
2	↑	↓	←	→
3	BARRIER SW	MENU	WIDE	TELE

Table 4-2. Key Operation

4. Power Supply Control

The 8-bit microprocessor controls the power supply for the overall system.

The following is a description of how the power supply is turned on and off. When the battery is attached, IC531 is operating and creating 3.7 V (POWER ON: 3.7 V → 5.3 V), a regulated 3.2 V voltage is normally input to the 8-bit microprocessor (IC301) by IC302, clock counting and key scanning is carried out even when the power switch is turned off, so that the camera can start up again.

When the power switch is off, the 8-bit microprocessor halts 4 MHz of the main clock, and operates 32.768 kHz of subclock.

When the battery is removed, the 8-bit microprocessor power switches the battery for memory backup by IC302, and operates at low consumption. At this condition, the 8-bit microprocessor halts 4 MHz of the main clock, and operates clock counting by 32.768 kHz of sub clock.

Also, the battery for backup is charged 10 hours from it to be attached.

When the power switch is on, the 8-bit microprocessor starts processing. The 8-bit microprocessor first sets both the PON signal at pin (34), the PAON signal at pin (35) and PAON2 signal at pin (53) to High, and then turn on the power circuit. After PON signal is to High, sets external port of ASIC after approximately 100 ms. According to setting of this external port, carry out setting of the operating frequency and oscillation control in the ASIC. Also, it starts communication with ASIC, and confirms the system is operative.

When the through image is operating, set the PAON signal and the PAON2 signal to High and then turn on the CCD. When the through image is playing, set the PAON signal and the PAON2 signal to Low and then turn off the CCD. When LCD panel turns on, set LCD ON1 signal at pin (22) and LCD ON2 signal at pin (23) to High, and then turn on the power. Set the LCD_BL signal from the ASIC to High, and turn on the backlight power.

When the power switch is off, the lens will be stowed, and PON, PAON, PAON2, LCD ON, LCD ON2 and LCD BL signals to Low and the power supply to the whole system is halted. The 8-bit microprocessor halts oscillation of the main clock (4 MHz), and set operation mode of clock ocillation (32.768 kHz).

	ASIC, memory	CCD	8bit CPU	LCD MONITOR
Power supply voltage	1.41 V, 3.25 V	12.0 V, -6.0 V 3.45 V	3.2 V	15 V, 5 V
Power OFF	OFF	OFF	32KHz	OFF
Playback mode	ON	OFF	4MHz	ON
Shooting mode (LCD)	ON	OFF	4MHz	ON
Shooting mode (OVF)	OFF	OFF	4MHz	OFF
Shooting	ON	ON	4MHz	ON
USB connection	ON	OFF	4MHz	OFF

Table 4-3. Power supply control

総合結線図
OVERALL WIRING

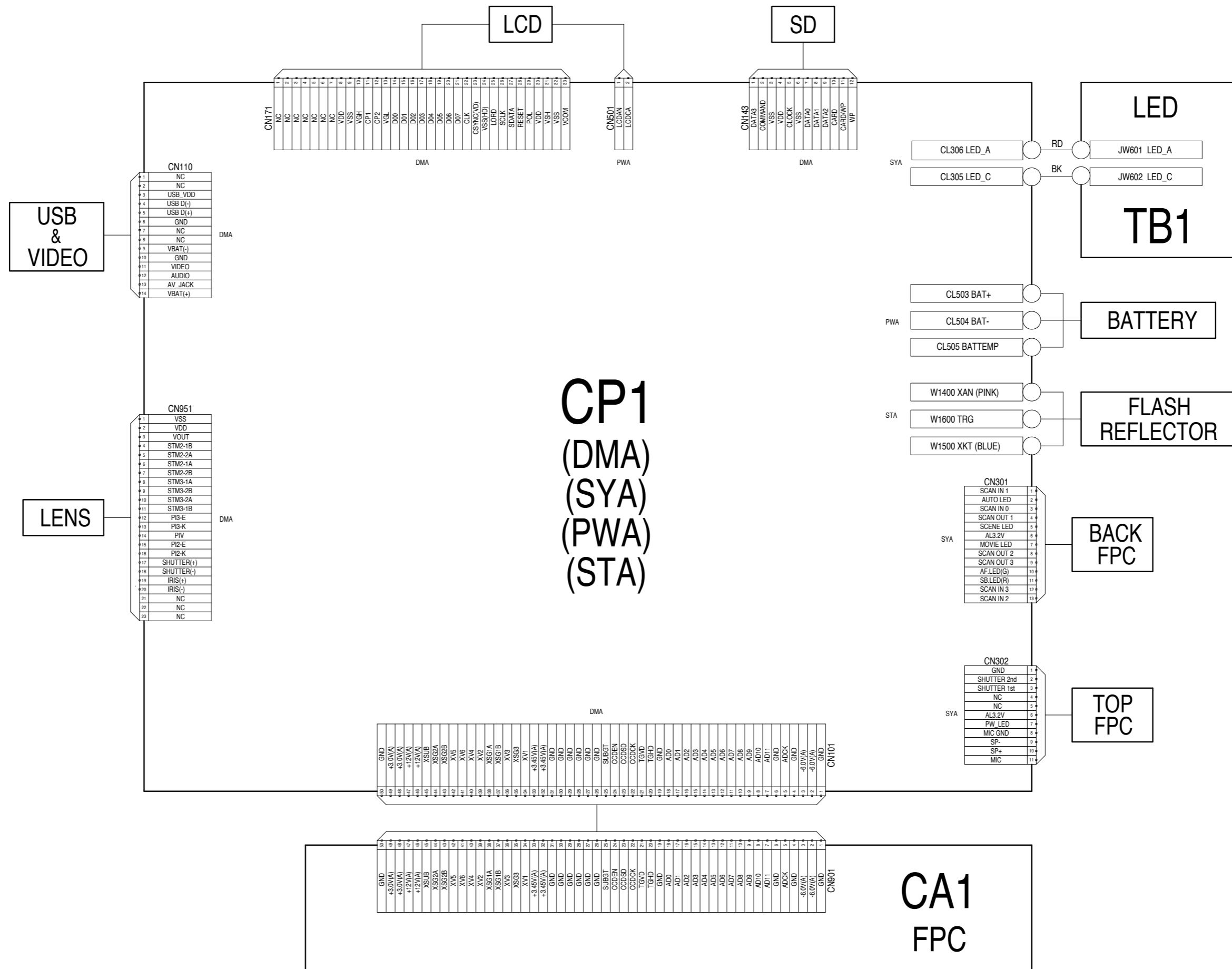

CP1 (DMA) 回路图 CP1 (DMA) CIRCUIT DIAGRAM

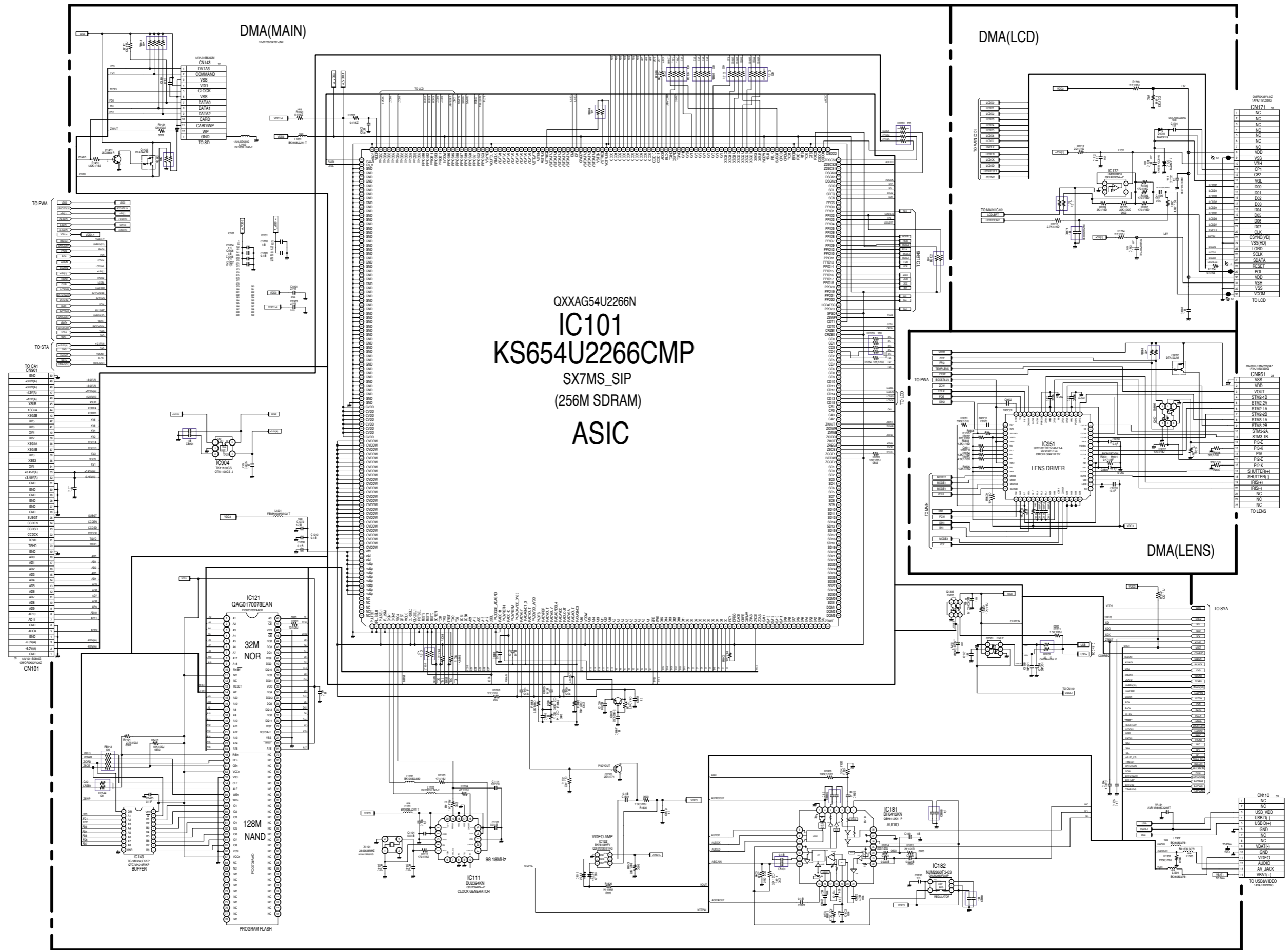

QXXAG54U2266N
IC101
KS654U2266CMP
SX7MS_SIP
(256M SDRAM)
ASIC

CP1 (SYA) 回路図
CP1 (SYA) CIRCUIT DIAGRAM

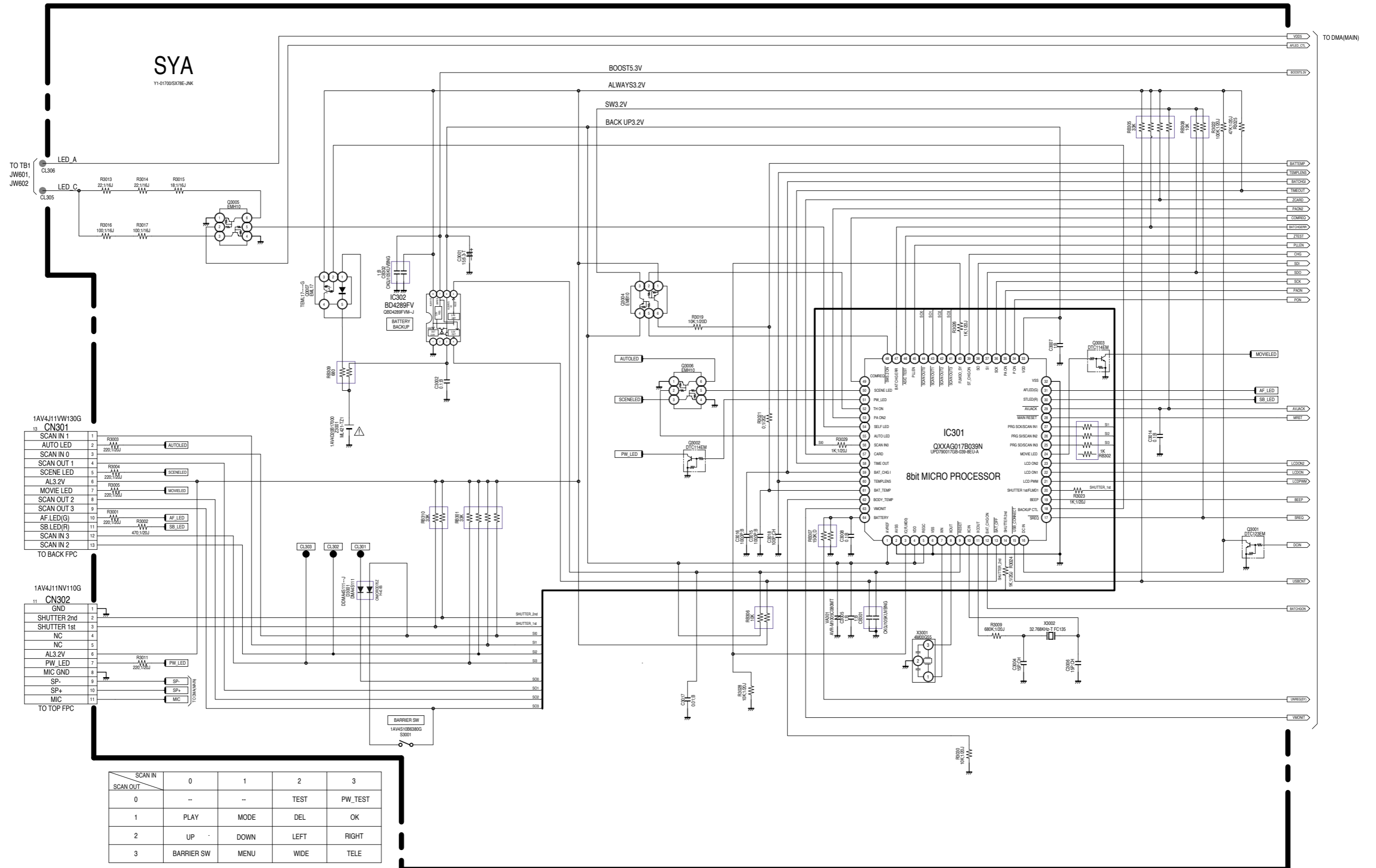

SCAN IN \ SCAN OUT	0	1	2	3
0	--	--	TEST	PW_TEST
1	PLAY	MODE	DEL	OK
2	UP	DOWN	LEFT	RIGHT
3	BARRIER SW	MENU	WIDE	TELE

CP1 (PWA) 回路図 CP1 (PWA) CIRCUIT DIAGRAM

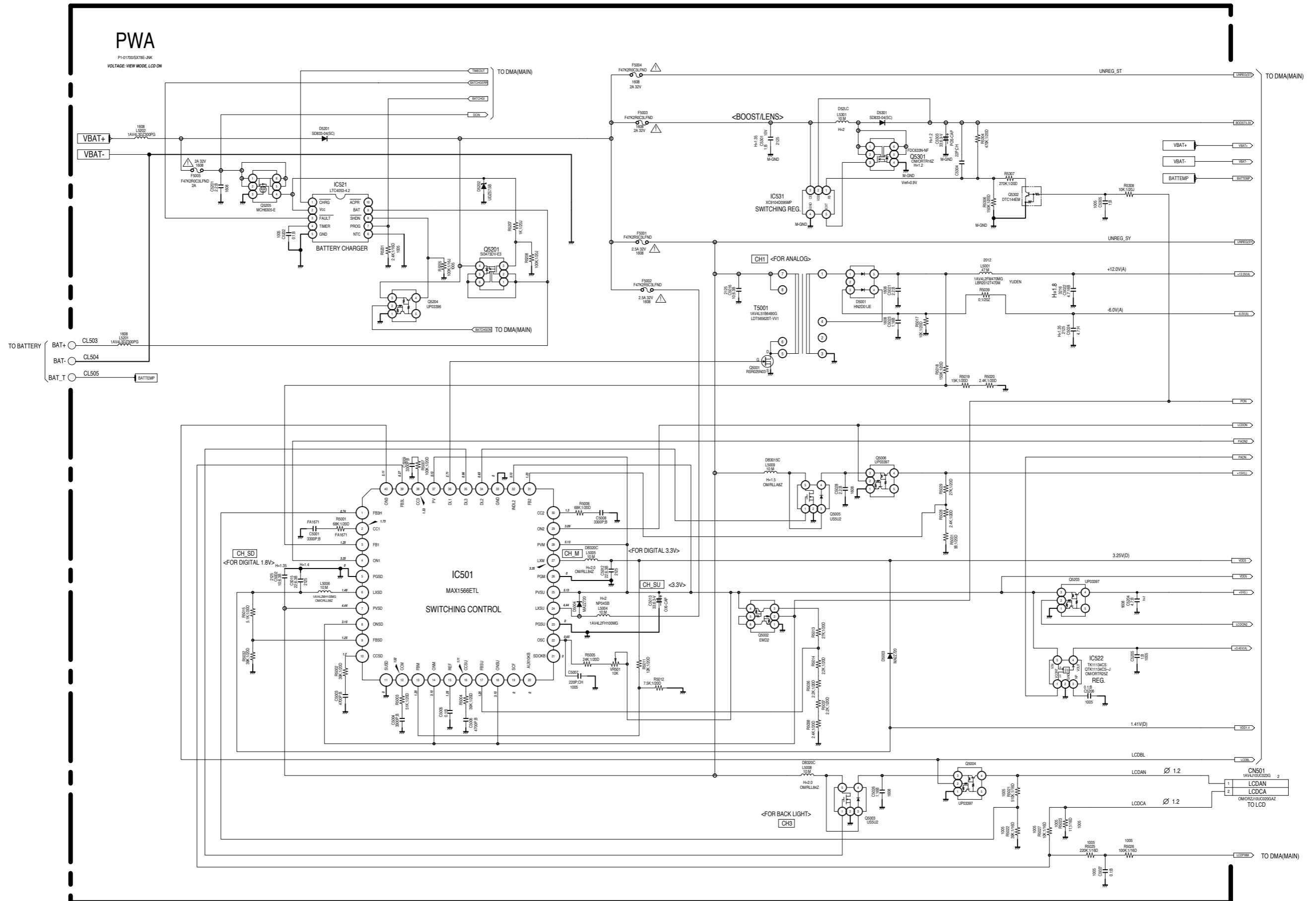

CP1 (STA) 回路図
 CP1 (STA) CIRCUIT DIAGRAM

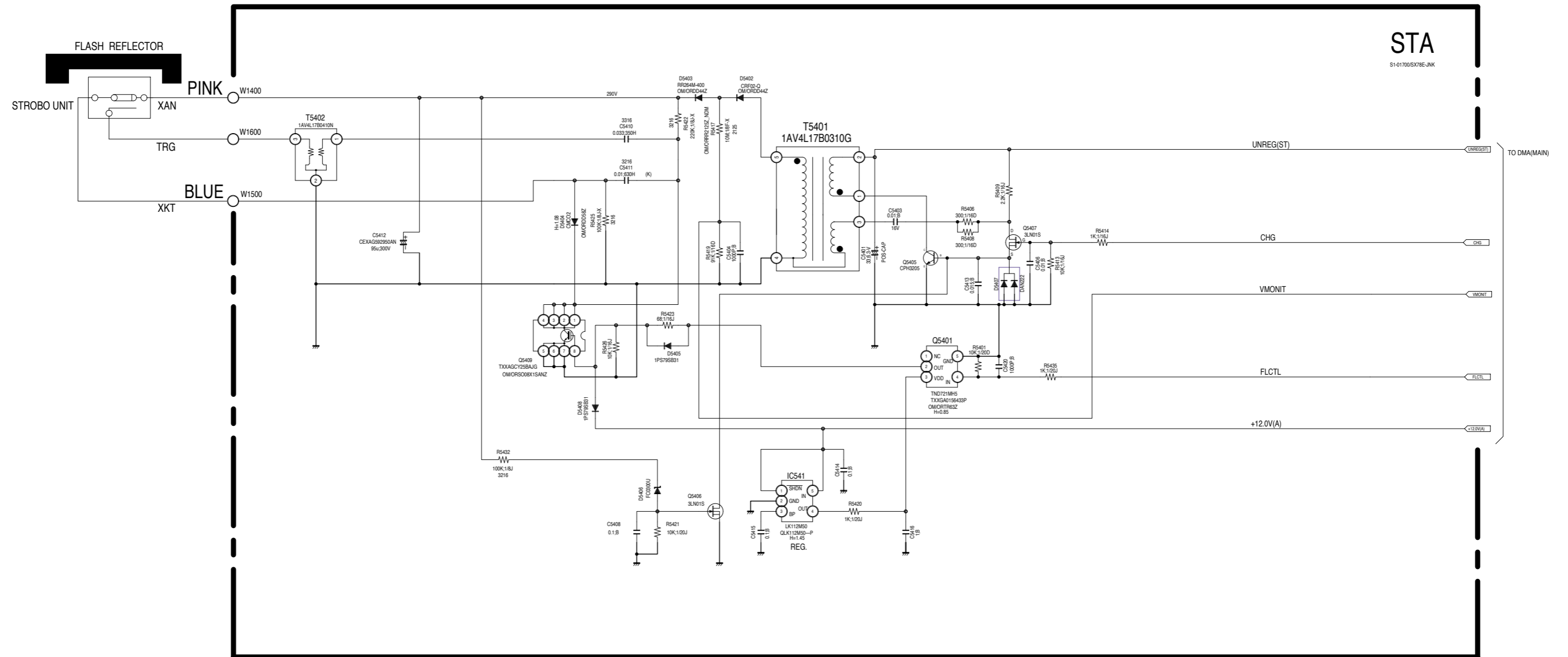

TB1 回路图
TB1 CIRCUIT DIAGRAM

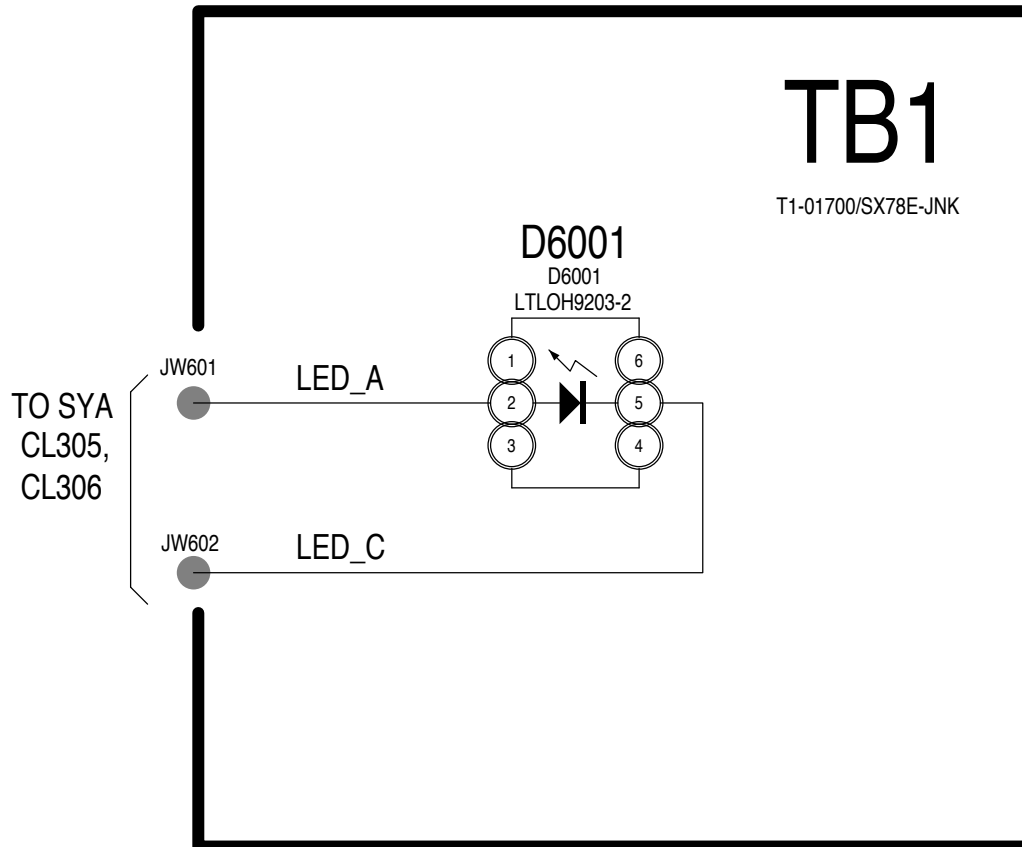

CA1 回路図
CA1 CIRCUIT DIAGRAM

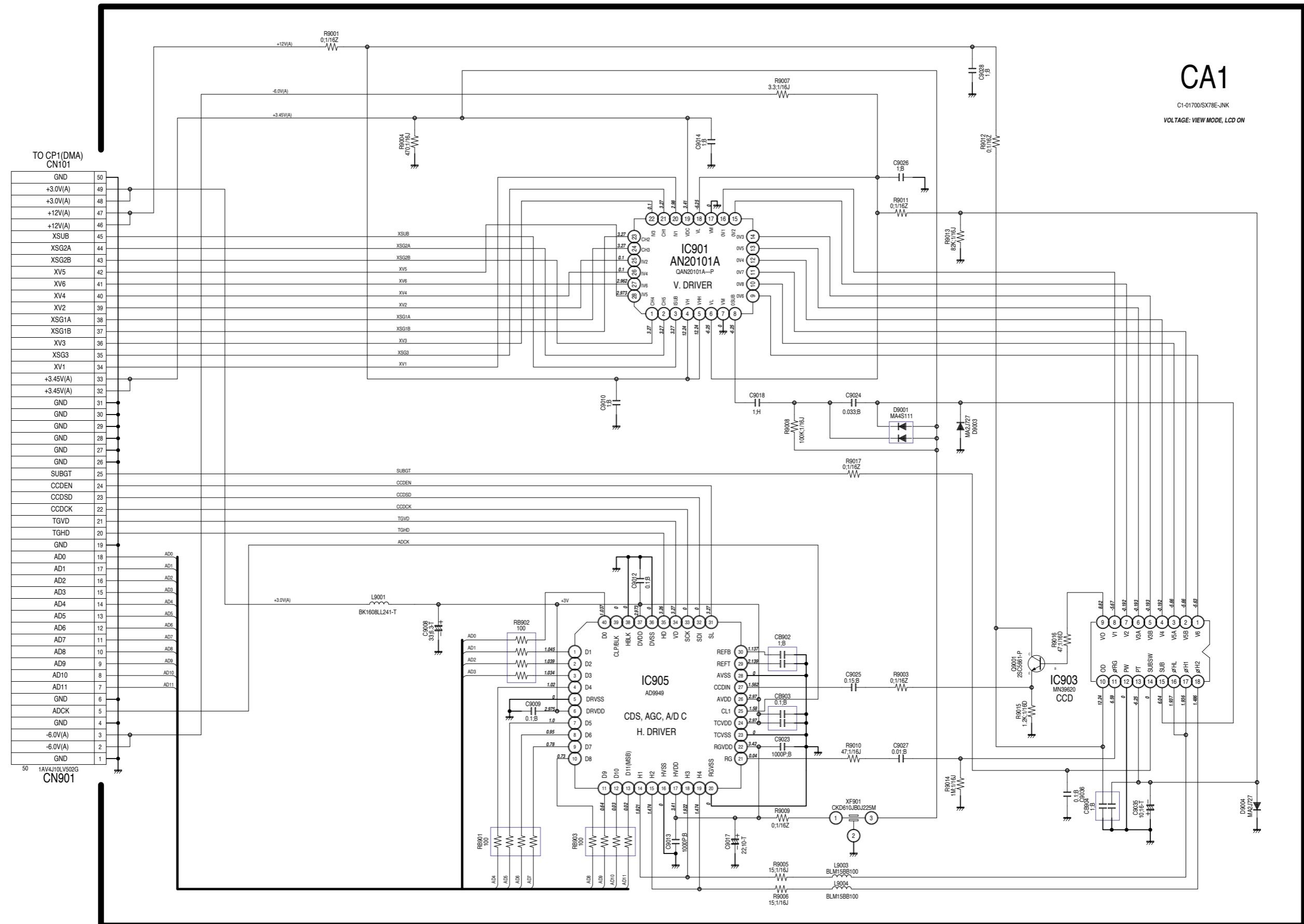

ASIC ブロック図
ASIC BLOCK DIAGRAM

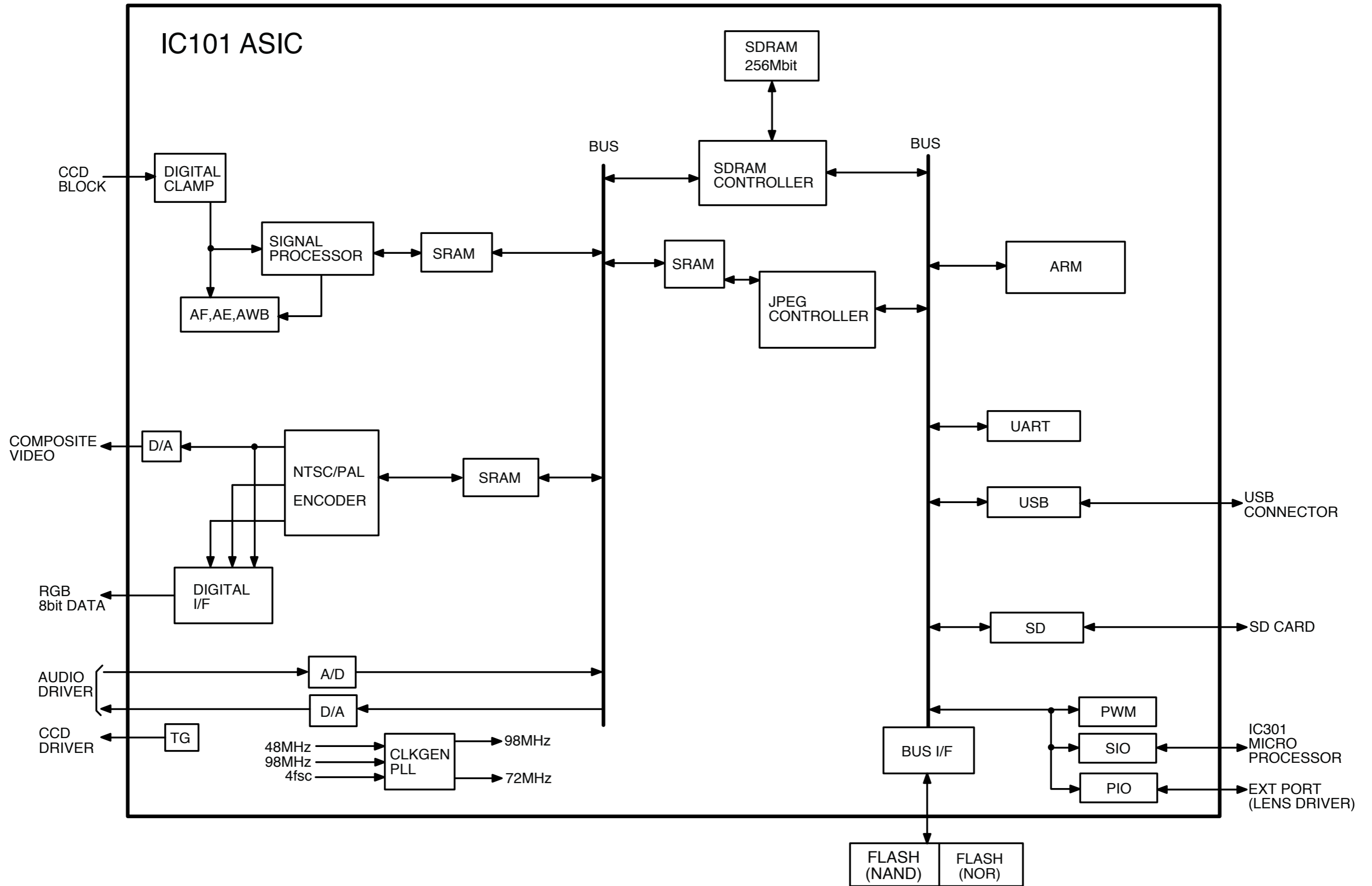

CCD ブロック図 CCD BLOCK DIAGRAM

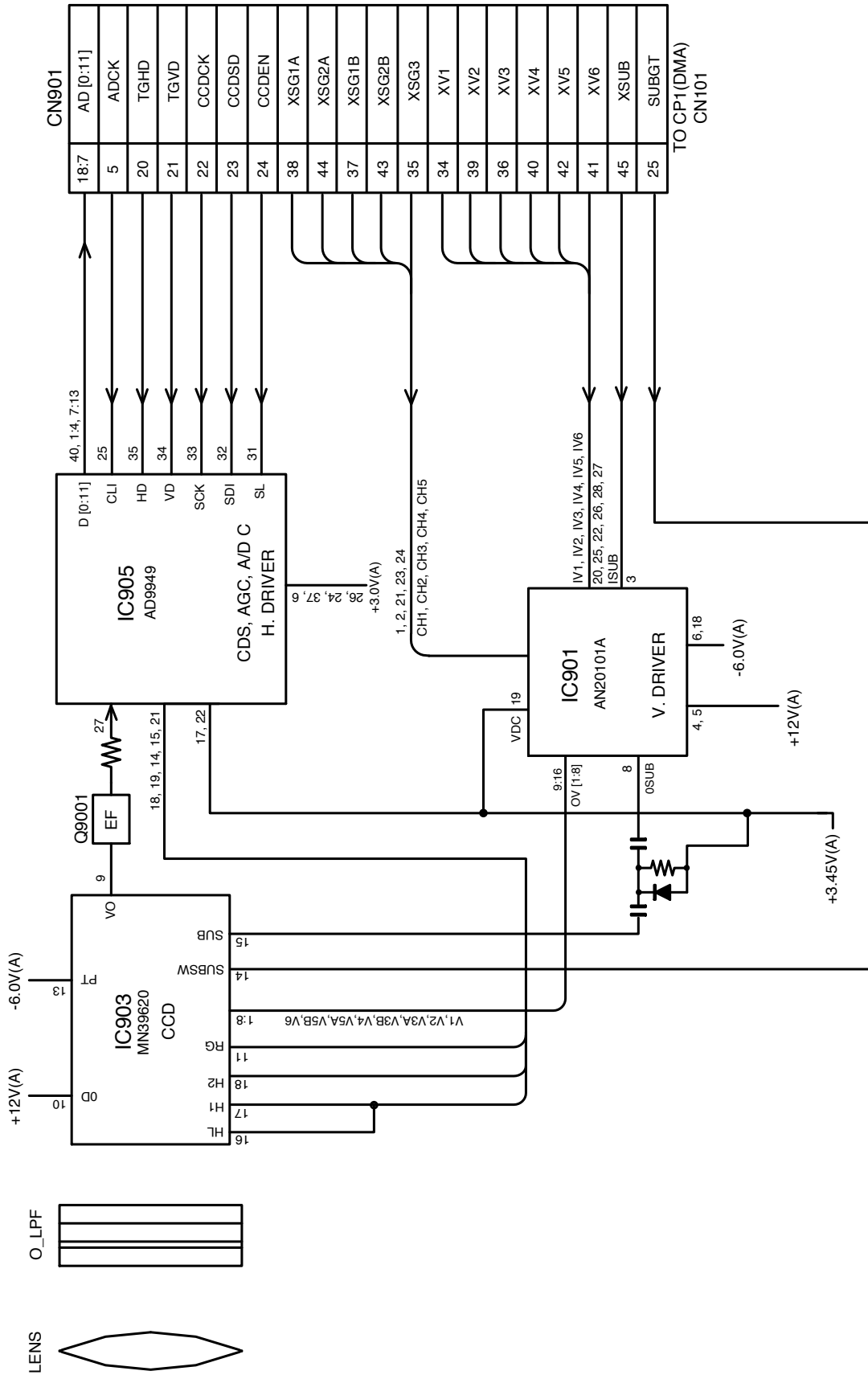

LENS ブロック図

LENS BLOCK DIAGRAM

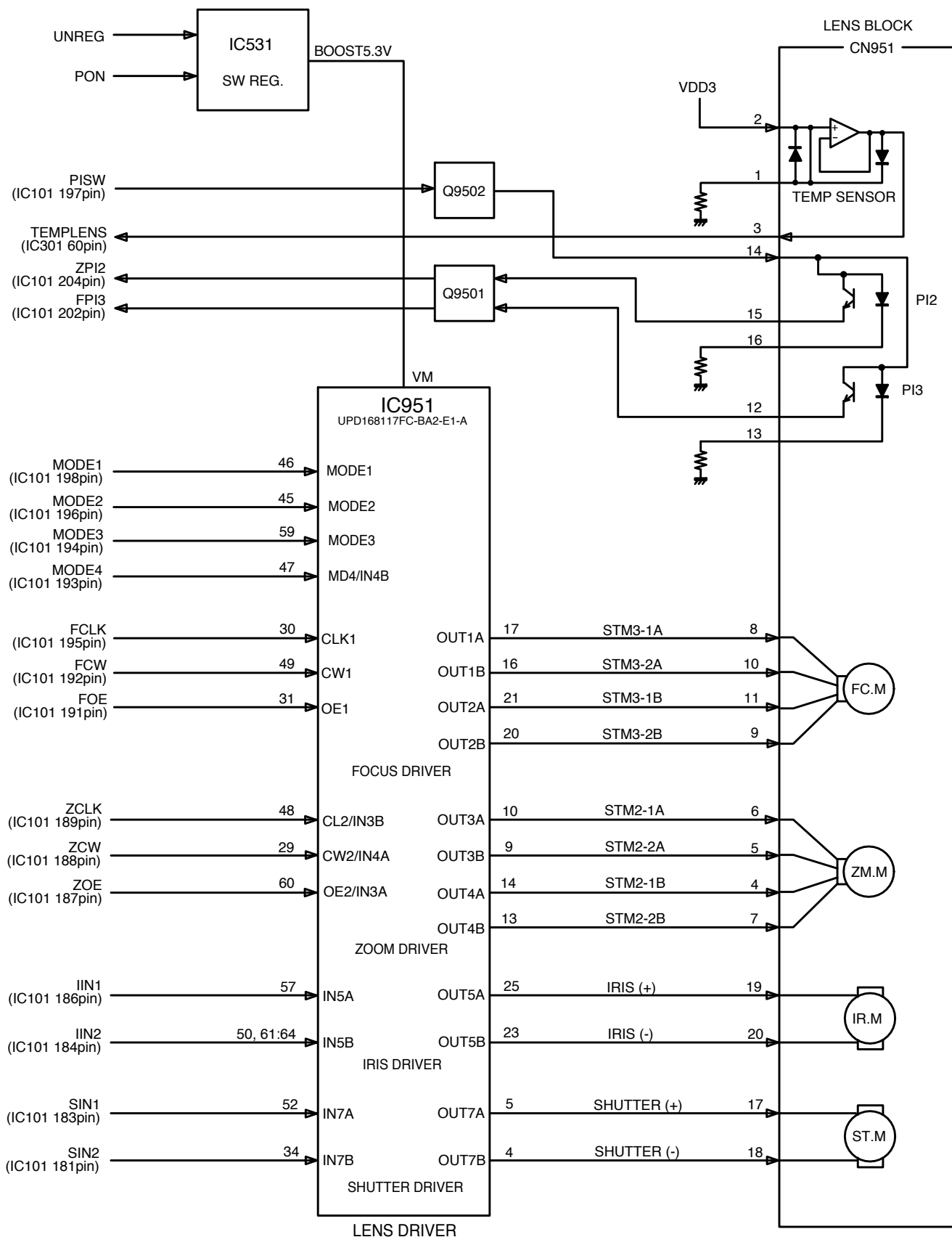

OVERALL ブロック図
OVERALL BLOCK DIAGRAM

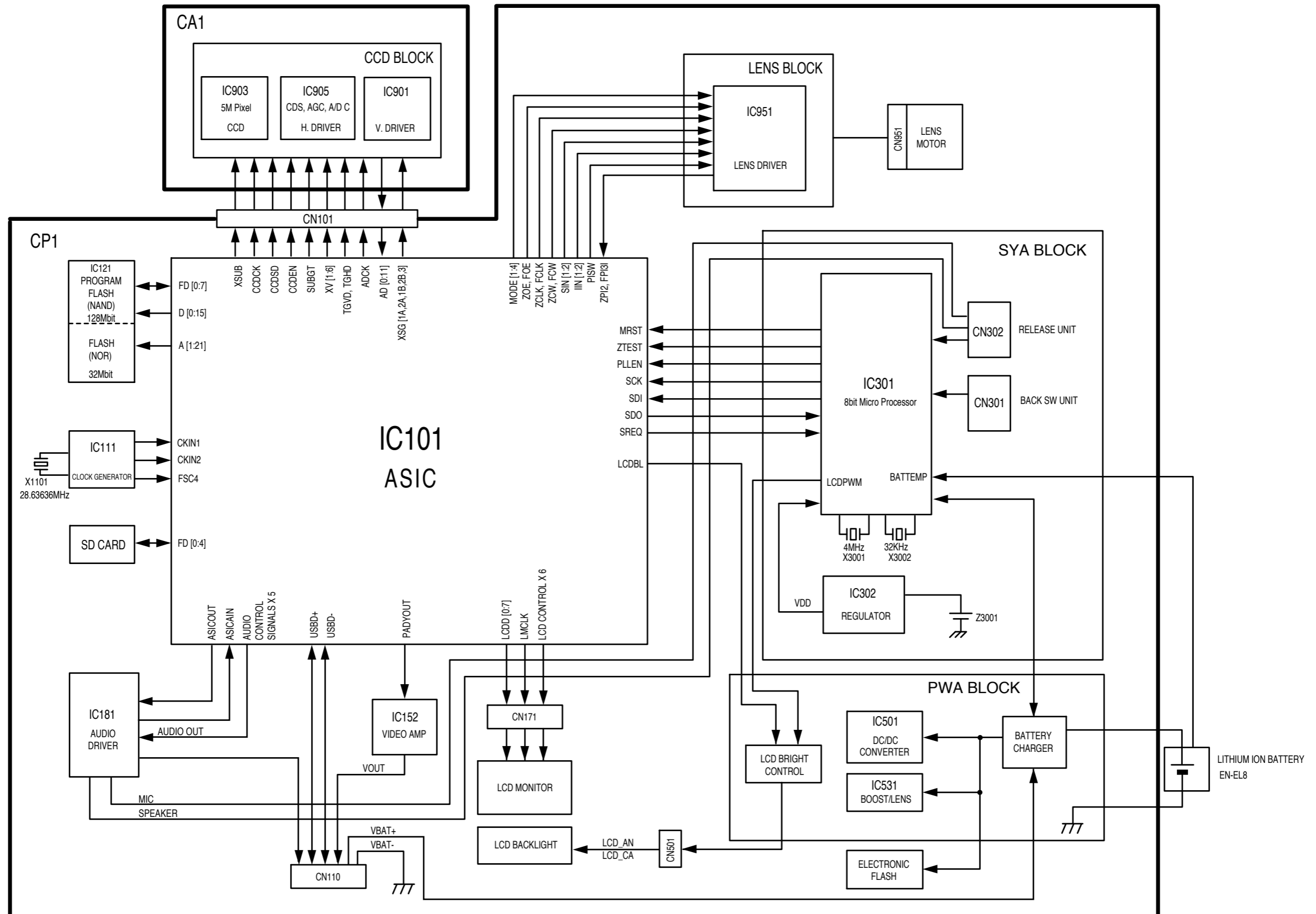

SYSTEM CONTROL ブロック図
SYSTEM CONTROL BLOCK DIAGRAM

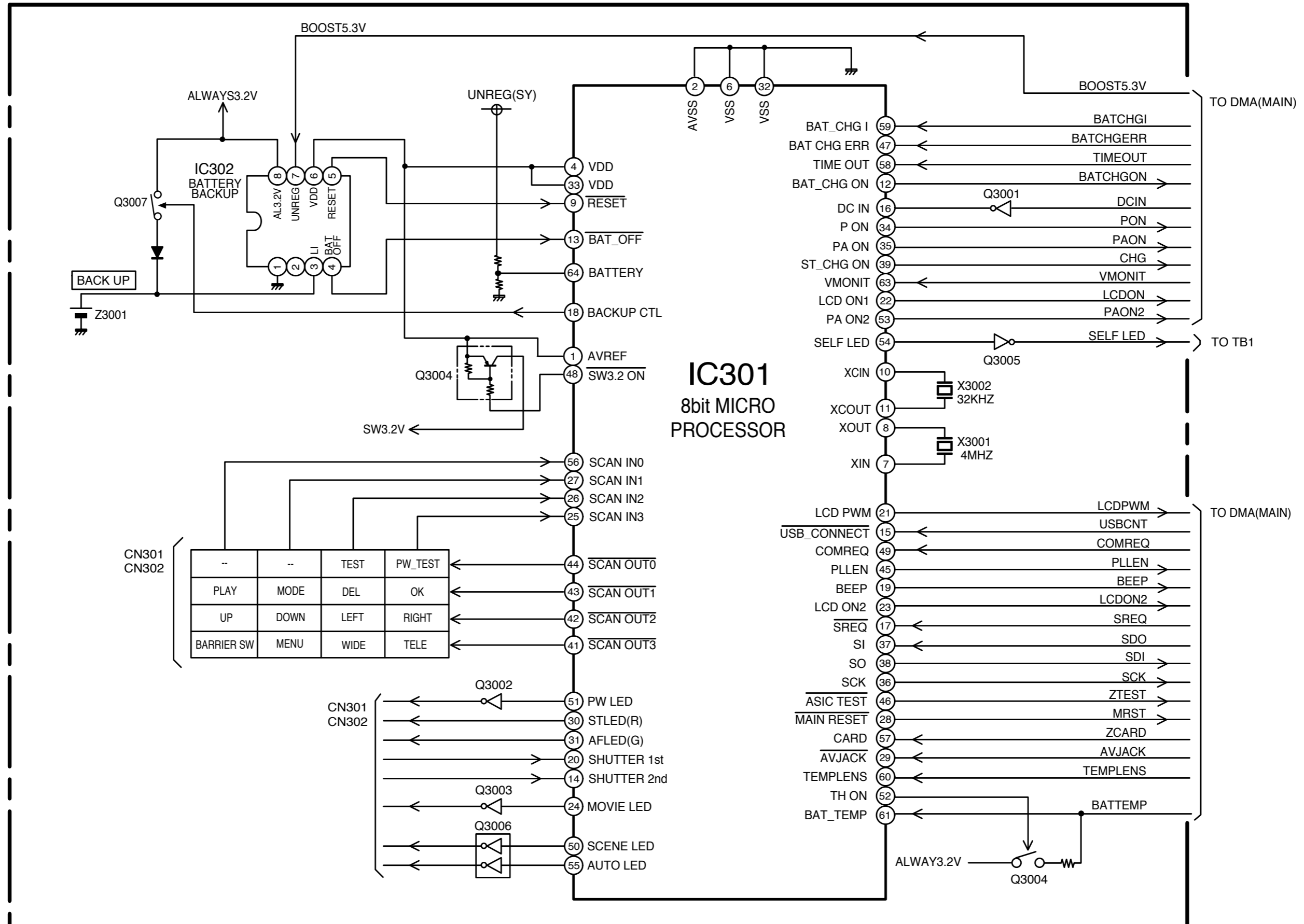

POWER ブロック図 POWER BLOCK DIAGRAM

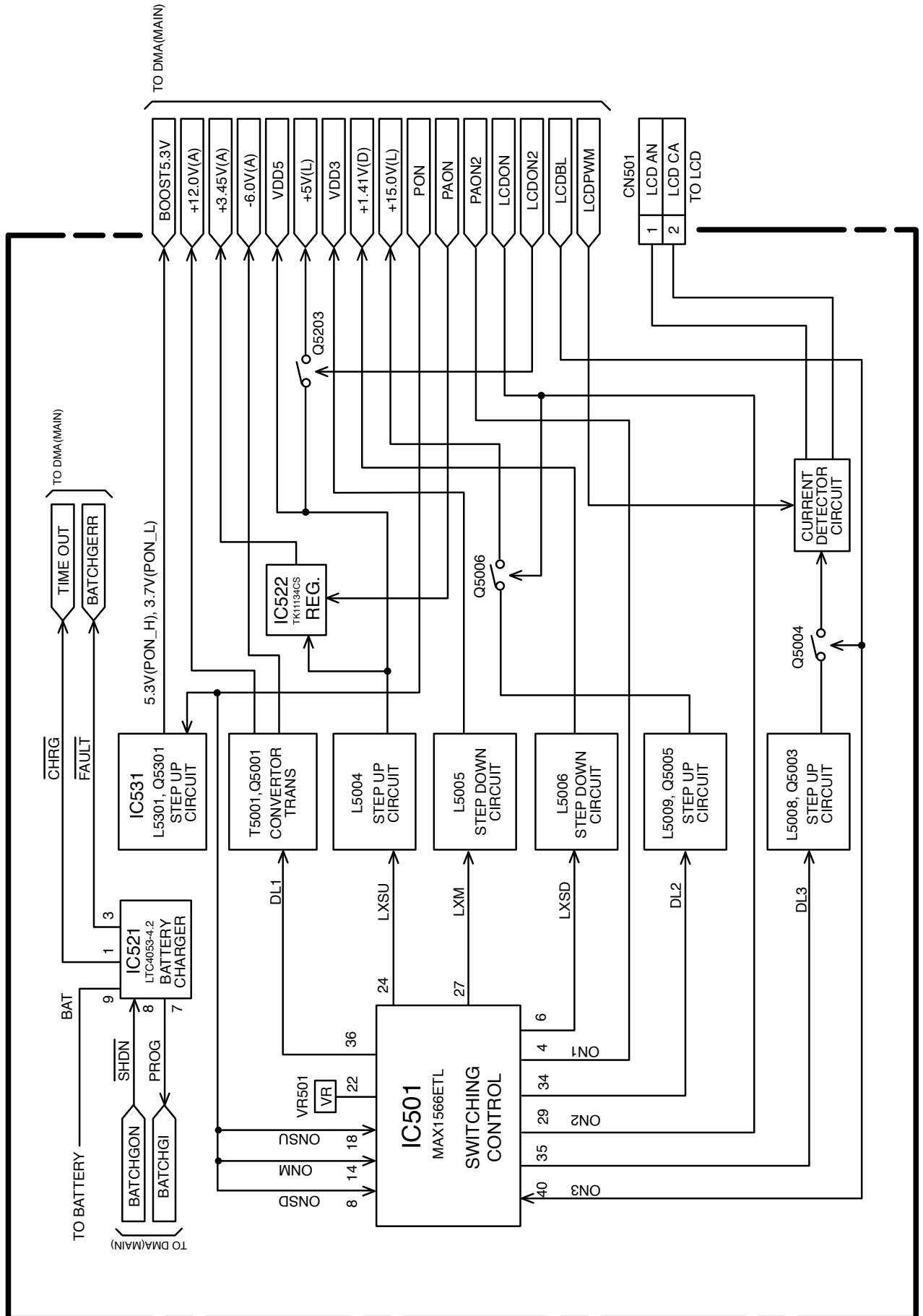

FUSE ARRANGEMENT (CP1 PCB)

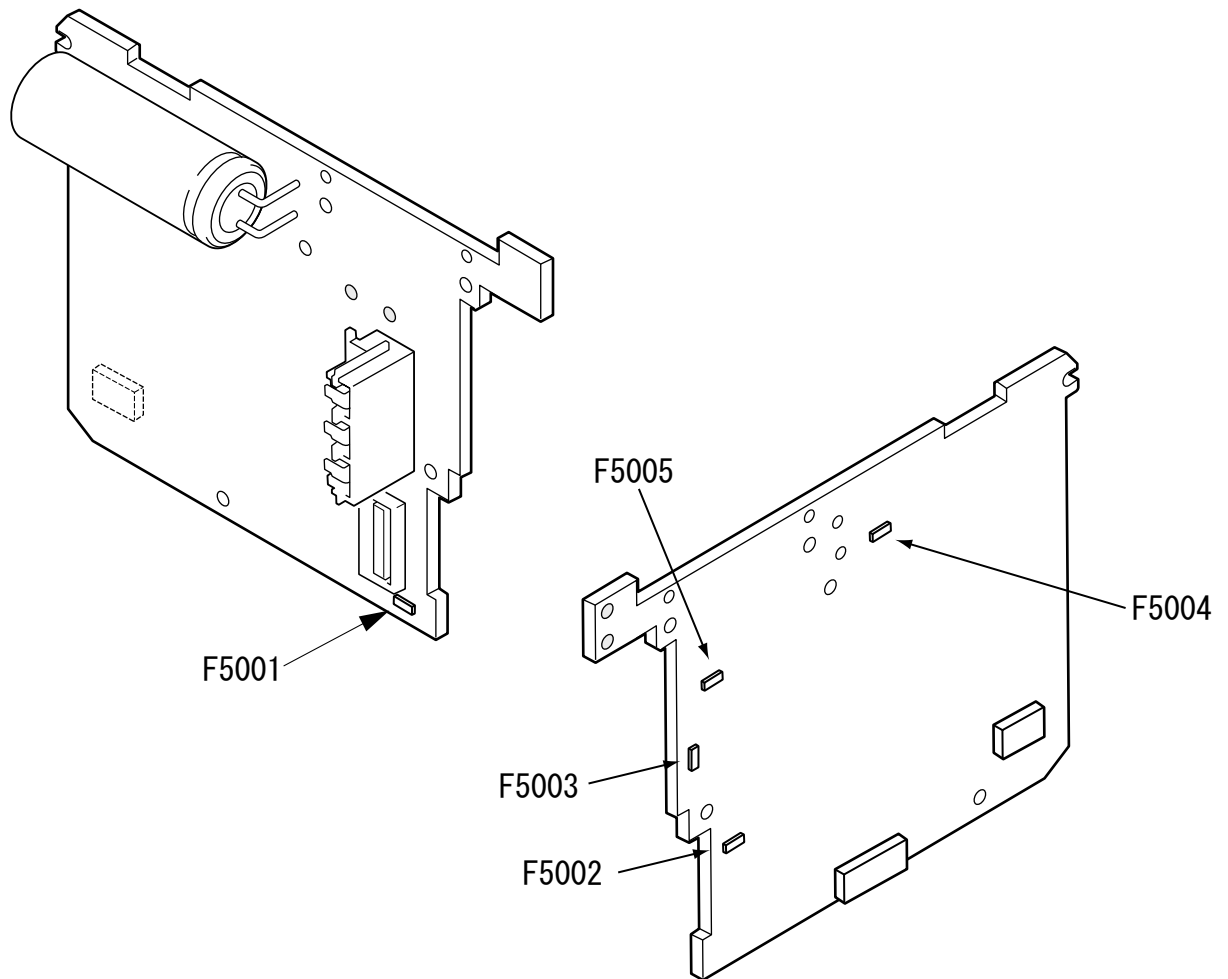

FUSE	Function of FUSE	Phenomenon when FUSE has blown out	Rating
F5001	Used to protect the DC/DC converter circuit.	The power of the camera is not turned on.	32V/2.5A
F5002	Used to protect the DC/DC converter circuit.	The power of the camera is not turned on.	32V/2.5A
F5003	Used to protect the lens motor/system computer power circuit.	The power of the camera is not turned on.	32V/2A
F5004	Used to protect the speed light charging circuit.	The speed light cannot be charged.	32V/2A
F5005	Used to protect the battery charging circuit.	The battery cannot be charged.	32V/2A

The contents of inspection standards and tools for S2

[1] Inspection standards	R1 to R11
[2] Tools	T1 to T4

INSPECTION STANDARDS

Item	Criteria	Applied tool(s)
<p data-bbox="188 275 339 304">External view</p> <p data-bbox="212 327 408 398">Gap/Difference in height</p> <p data-bbox="212 853 408 925">Outside and inside status</p>	<ul style="list-style-type: none"> <li data-bbox="499 327 738 356">• General components <li data-bbox="515 378 727 407">Gap: 0.3mm or less <li data-bbox="515 430 911 459">Difference in height: 0.15mm or less <li data-bbox="515 481 1102 510">※ The 0.2mm convex section on the strap is excluded. <li data-bbox="499 533 946 562">• When the battery case is opened/closed: <ul style="list-style-type: none"> <li data-bbox="544 573 1046 602">Gap: 0.15mm or less (Front surface of camera) <li data-bbox="544 624 1067 654">Gap: 0.2mm or less (Others except front surface) <li data-bbox="544 676 906 705">Difference between right and left: <ul style="list-style-type: none"> <li data-bbox="571 716 866 745">0.08mm or less (periphery) <li data-bbox="571 768 956 797">0.15mm or less (stepped difference) <li data-bbox="544 819 911 848">Stepped difference: 0.3mm or less <li data-bbox="499 871 1185 925">• There must be no noticeable damage, stain, sink mark, welded mark, unevenness, crack or oil exudation. <li data-bbox="499 947 1222 1070">• When pushing the main body, noticeable noise must not be heard. (Observe and check it by naked eyes under fluorescent lamp and natural sunshine.) 	<p data-bbox="1252 327 1453 356">Visual observation</p> <p data-bbox="1252 853 1453 882">Visual observation</p>
<p data-bbox="188 1137 427 1167">Operation/Operability</p> <p data-bbox="212 1189 427 1261">Operation/Shaking/ Shock</p> <p data-bbox="212 1518 456 1590">Operability of buttons/ PWS</p>	<ul style="list-style-type: none"> <li data-bbox="499 1189 1206 1261">• While operating, any irregularities or irregular noise shall not be required. <li data-bbox="499 1283 1198 1451">• Operation must be normal. (Check it by shaking the camera while operating.) (While operating, tap the camera by your palm and hit it lightly onto the Linoleum-laid desk.) <li data-bbox="499 1518 991 1547">• No cave-ins of the buttons shall be required. <li data-bbox="499 1570 967 1599">• Operator must feel "click" on each button. <li data-bbox="499 1621 1206 1789">• "Click" must occur when or after a switch is ON. (Check it while operating normally.) (Check it by pushing one-sidedly, pushing lightly, holding down and pushing with chatter.) 	<p data-bbox="1252 1189 1453 1218">Secondary battery</p>

Item	Criteria	Applied tool(s)
Operation/Operability		
Operation touch	<ul style="list-style-type: none"> • When operating a lever or knob by hand, any irregular conditions shall not be required. (Operate the camera in the actual photography procedure and check the operation touch.) 	
Battery/card cover	<ul style="list-style-type: none"> • When closed, there must not be an extreme play and the waterproof effect must be kept surely. • The cover can be opened/closed without any outstanding "caught-in-mechanism" touch or "rubbed-in-mechanism" touch. • While the cover is opened, it should be set at the open stopper. • At the closed position, there must be no problem for the waterproof effect. • In the battery cover sliding/rotating operation that is permitted for the user, there must not be any outstanding "caught-in-mechanism" touch or damage. • When the cover is opened, the operation must not be hindered by the suction of silicone rubber. • The packing must not fall off. 	
Multi-connector cover	<ul style="list-style-type: none"> • The cover can be opened/closed correctly. • When closed, there must not be an extreme play and there must be no problem for the waterproof effect. • When opened, the top surface of the cover must not interfere with the bottom of the camera and the cover can be rotated. • In the opening/closing/rotating operation that is permitted for the user, there must not be any outstanding "caught-in-mechanism" touch or damage. • The O-ring, which is fixed on the cover, must not fall off. 	

Item	Criteria	Applied tool(s)
Barrier	<ul style="list-style-type: none"> • The barrier can be opened/closed smoothly without any "caught-in-mechanism" touch. • When the barrier is opened, it must move to the stopper correctly and the power must be ON. • When the barrier is closed, it must move to the stopper correctly and must block the opening of the front cover and the hairline unit. • In the opening/closing operation, the camera body and barrier must not be damaged. • When the barrier is opened, there must be no shading in the photographed image (in the whole zoom area). • The barrier must not have any play. • The barrier opening/closing position must not be deviated by a light shock. • The barrier switch must not be activated by a light shock. • When the barrier switch is ON, there must be no shading in the lens. (W ~ T) • When releasing the barrier at the barrier switch ON position, the barrier must be opened to its open stopper position. • When opened/closed, there must be no noise. <p>(Check visually by operating the barrier.)</p> <p>(Check visually as watching from the camera front.)</p>	
Lens capacity Focal length	<p>Wide-end position (Compelling ∞)</p> <p style="padding-left: 20px;">5.8 mm + 7%</p> <p style="padding-left: 40px;">- 1%</p> <p>Tele-end position (Compelling ∞)</p> <p style="padding-left: 20px;">17.4 mm + 1%</p> <p style="padding-left: 40px;">- 7%</p> <p>(Perform measurement by using the single unit of lens barrel.)</p> <p>(Perform measurement at the "∞" position.)</p>	Focal length measuring instrument Lens drive tool

Item	Criteria	Applied tool(s)
Lens capacity Open aperture F No.	Wide-end position (Compelling ∞) F3.0 + 8.0% - 0% Tele-end position (Compelling ∞) F5.4 + 10.4% - 0% (Calculate the value by using the actual measurement focal length.) (Perform measurement by using the single unit of lens barrel.) (Perform measurement at the " ∞ " position.)	Lens drive tool
Peripheral light reduction	<ul style="list-style-type: none"> • Against the picture center, the luminance of the nearest peripheral area must be 35% or more. • Against the picture center, the luminance at 70% of the image height must be 55% or more. • The difference between right and left in luminance must be 20% or less. (Body actual photography) (Take a picture of the 5100K viewer for checking.) (Check it with "Wide" and "Tele".) (Check it at the near distance position and at the "infinity" position.) (Check it under the condition of aperture "open" and "without ND".)	Photoshop viewer
Ghost/Flare Point light source Surface light source	<ul style="list-style-type: none"> • There must not be an outstanding ghost/flare. • There must not be an outstanding flare at the center. (When the weather is fine, take a picture with rear light at the vertical and horizontal positions. Then, check the picture through the monitor.) (Check it under the condition of aperture "open" and "without ND" and also, "with ND".) (Check it in the whole area of FOCUS/ZOOM.) (Take a picture of the object with high luminance at its periphery and low luminance at its center, and take another picture of the object with low luminance at its periphery and high luminance at its center. Check the pictures through the monitor.)	Visual observation

Item	Criteria	Applied tool(s)									
Lens capacity Distortion Dust in a picture	<ul style="list-style-type: none"> • There must not be an outstanding deformation. (Take a picture of the linear object in its vertical and horizontal positions to check it.) • There must not be an outstanding dust in a picture. • When the picture center (within the circle whose diameter is 80% of the short side) is Zone I and its outside is Zone II, the light reduction against the periphery must be as follows : <table border="1" data-bbox="517 640 951 748"> <thead> <tr> <th></th> <th>a</th> <th>b</th> </tr> </thead> <tbody> <tr> <td>Zone I</td> <td>4 or less</td> <td>0</td> </tr> <tr> <td>Zone II</td> <td>10 or less</td> <td>2 or less</td> </tr> </tbody> </table> <p>a: 1.5% or less b : More than 1.5% and less than 3.0%</p> <p>(Take a picture of the 5100K viewer under the condition of the "T" end, aperture "open" and "without ND" and also, "with ND". Check the image.) (Check it by PC.)</p>		a	b	Zone I	4 or less	0	Zone II	10 or less	2 or less	Photoshop CRT monitor PC
	a	b									
Zone I	4 or less	0									
Zone II	10 or less	2 or less									
Lens barrel Image shaking	<ul style="list-style-type: none"> • The image center deviation in "W ⇔ T" zoom must be 2.5% or less of the screen short side length. • There must not be any abnormal operation such as folding motion or "caught-in-mechanism" motion. (Fit the center positions of "W" and "T" and check the center shaking during zoom operation.) (Display a through-the-monitor image on the 20-inch monitor to check it.) (As changing the camera's posture, check it in all the directions.) 	Special chart 20-inch monitor									
AF Distance measurement operation Shortest photograph distance Normal Macro	<ul style="list-style-type: none"> • In the case of normal AF: Focus must be fit at the picture center. • In the case of the out-of-focus object: Focus must be fit at the 2m point. • In the case of the scene mode: Focus must be fit in the selected area. ("Picture center" means the area encircled by 1/4 of the vertical and horizontal length of the photography range.) (Measure the distance of the area displayed on LCD to check it.) <p>Focus must be fit at the following distance.</p> <ul style="list-style-type: none"> • 30cm (in whole area) • 14cm (Z00), 4cm (Z03), 14cm (Z06) <p>(Perform measurement at the distance from the end (G1) of lens barrel.) (Set the mode to "Macro".)</p>	Visual observation Tape measure									

Item	Criteria	Applied tool(s)
Shooting with a speed light	<ul style="list-style-type: none"> • Tele-end: 0.3 ~ 1.4m • Wide-end: 0.3 ~ 2.5m • Macro-wide-end 0.3 ~ 2.5 m In the above range, ± 0.5 Ev or less (Photography mode: AUTO , • Speed light: Compelling flash)	Standard reflection plate
Light adjustment accuracy	<ul style="list-style-type: none"> • 5.5 ± 0.4 EV (Charge for 10 seconds with the full-charged secondary battery and perform measurement within 1 second.)	Flash meter Battery
Guide No. FULL (ISO100 • m)	<ul style="list-style-type: none"> • Within 6.5 seconds • Perform charging with a full-charged secondary battery for 10 seconds and carry out full flashing within 1 second. Then, measure the time taken until the speed light LED finishes blinking while pressing lightly the shutter release button. 	Stop watch Battery
Recycling time	<ul style="list-style-type: none"> • Wrong flash must not occur. (Check by loading/unloading a battery, giving a light shock and operating mode buttons except S2.)	Battery
Wrong flash		
Quality of image (Photography with EIAJ chart)	<ul style="list-style-type: none"> • The resolution must be in compliance with the following values in all the postures of the EIA J chart evaluation. <High quality of image> Center horizontal/vertical: 1150 TV pcs. Periphery horizontal/vertical: 750 TV pcs. • Take a picture on condition that the camera is in the status of aperture "open" and "without ND" while "AUTO" and the image quality priority mode are set. • Equip the 5100K viewer with a chart in all the positions and at the distance of 0.3m or more and shoot an object in the full range of angle of view. • Then, open the recorded image data file through Photoshop and check the resolution visually. • Check each posture and the difference of zoom reciprocation. 	EIAJ chart Photoshop Siemens chart
Resolution in AF (10 ~ 0.3m)	<ul style="list-style-type: none"> • The resolution must be in compliance with the following value in the whole zoom area. Center horizontal/vertical: 1150 TV pcs. • Measure the TV resolution pieces at center. • Check each posture and the difference of zoom reciprocation. 	EIAJ chart Photoshop Siemens chart

Item	Criteria	Applied tool(s)
Quality of image (0.3m ~ 0.04m)	<ul style="list-style-type: none"> • The resolution must be in compliance with the following value in the whole zoom area. Center horizontal/vertical: 950 TV pcs. • Measure the TV resolution pieces at center. • Check each posture and the difference of zoom reciprocation. 	EIAJ chart Photoshop Siemens chart
Resolution in "Macro"	<ul style="list-style-type: none"> • Center horizontal/vertical: 950 TV pcs. • Check the resolution in near distance (W14cm, M (Z03) 4cm and T14cm). • Take a picture at the high image quality mode. 	EIAJ chart Photoshop Siemens chart
In the case of compelling infinity	<ul style="list-style-type: none"> • The resolution must be in compliance with the following value in the whole zoom area. Center horizontal/vertical: 950 TV pcs. • Take a picture of the infinity collimator image at the landscape mode/image quality priority mode under the "out of focus" condition by using the 3000K viewer. (This condition should be applied to only the product which uses the Q3035 lens barrel.) • Then, open the recorded image data file through Photoshop and check the resolution visually. 	Infinity chart
In the case of "out of focus"	<ul style="list-style-type: none"> • The resolution must be in compliance with the following value in the whole zoom area. Center horizontal/vertical: 950 TV pcs. • Measure the TV resolution pieces at center. • Check each posture and the difference of zoom reciprocation. • Put a chart at the distance of 2m, set it in the "out of focus" condition and shoot it. 	EIAJ chart Photoshop Siemens chart
Gradation/luminance level	<p data-bbox="491 1503 858 1536"><Histogram's gray average value></p> <ul style="list-style-type: none"> • Black: 7 ± 5 Gray: 140 ± 10 White: 215 ± 15 • Equip the 5100K viewer with a scale and shoot an object in the full range of angle of view while the AUTO mode and the image quality priority mode are set. • Open the recorded image data file through Photoshop and pick up a measurement section with the each color (its central area 64×64 pixels) with the rectangle selector tool. • Read the histogram's gray value and the gray standard deviation. • Measurement section Luminance level: Upper left 1 step: Black, 6 steps: Gray, Center: White Lower left 6 steps: Gray, 11 steps: Black 	5100K viewer ITE γ 0.45 Gray scale (standard) Photoshop

Item	Criteria	Applied tool(s)																																
Quality of image Noise	<p><Histogram's standard deviation></p> <ul style="list-style-type: none"> • Gray: 3.0 or less Black: 3.0 or less • Equip the 5100K viewer with a scale and shoot an object in the full range of angle of view while the AUTO mode and the image quality priority mode are set. • Open the recorded image data file through Photoshop and pick up a measurement section with the each color (its central area 64×64 pixels) with the rectangle selector tool. • Read the histogram's gray standard deviation. • Measurement section Noise: Upper left 2 step: Black, 6 steps: Gray Lower left 6 steps: Gray, 10 steps: Black 	5100K viewer ITE γ 0.45 Gray scale (standard) Photoshop																																
Reproduction of color	<ul style="list-style-type: none"> • Color <table border="1" data-bbox="513 945 1027 1070"> <thead> <tr> <th></th> <th>R</th> <th>G</th> <th>B</th> </tr> </thead> <tbody> <tr> <td>W</td> <td>205 ± 20</td> <td>205 ± 20</td> <td>205 ± 20</td> </tr> <tr> <td>Ye</td> <td>200 ± 20</td> <td>210 ± 20</td> <td>35 ± 15</td> </tr> <tr> <td>R</td> <td>215 ± 20</td> <td>$0 - 25$</td> <td>$0 - 20$</td> </tr> </tbody> </table> • Vividness <table border="1" data-bbox="513 1137 1027 1263"> <thead> <tr> <th></th> <th>R</th> <th>G</th> <th>B</th> </tr> </thead> <tbody> <tr> <td>W</td> <td>205 ± 20</td> <td>205 ± 20</td> <td>205 ± 20</td> </tr> <tr> <td>Ye</td> <td>205 ± 20</td> <td>220 ± 20</td> <td>$0 - 35$</td> </tr> <tr> <td>R</td> <td>240 ± 20</td> <td>$0 - 25$</td> <td>$0 - 20$</td> </tr> </tbody> </table> • Equip the 5100K viewer with a chart and shoot an object in the full range of angle of view in the AUTO mode and the image quality priority mode. • Open the recorded image data file through Photoshop and pick up a measurement section with each color (its central area 64×64 pixels) with the rectangle selector tool. • Read the histogram's RGB. 		R	G	B	W	205 ± 20	205 ± 20	205 ± 20	Ye	200 ± 20	210 ± 20	35 ± 15	R	215 ± 20	$0 - 25$	$0 - 20$		R	G	B	W	205 ± 20	205 ± 20	205 ± 20	Ye	205 ± 20	220 ± 20	$0 - 35$	R	240 ± 20	$0 - 25$	$0 - 20$	Color bar chart Photoshop
	R	G	B																															
W	205 ± 20	205 ± 20	205 ± 20																															
Ye	200 ± 20	210 ± 20	35 ± 15																															
R	215 ± 20	$0 - 25$	$0 - 20$																															
	R	G	B																															
W	205 ± 20	205 ± 20	205 ± 20																															
Ye	205 ± 20	220 ± 20	$0 - 35$																															
R	240 ± 20	$0 - 25$	$0 - 20$																															

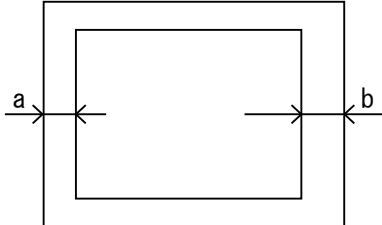
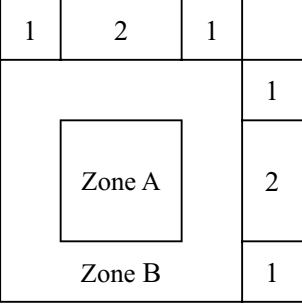
Item	Criteria	Applied tool(s)											
LCD and others Monitor LCD View	<ul style="list-style-type: none"> The reproduction of W, B and RGB must not be interfered. The monitor LCD must comply with the SY monitor LCD performance standard. There must be no shading in the LCD display range. The inclination of the image and the monitor frame must be $\pm 0.75^\circ$ or less. The vertical difference and horizontal difference of the black belt width in the image periphery must be within 0.3mm. (See the front of LCD to check it.) (Change to each mode and check for all the segments of LCD.) Vertical and horizontal difference: Difference between "a" and "b" 	Visual observation											
Visual field ratio	<ul style="list-style-type: none"> Through-the-monitor image: 96 to 100% Play-back image: 96 to 100% 	Visual observation											
Bright pixels or dim pixels on LCD	<ul style="list-style-type: none"> Perform reproduction for each single color of R, G, B and white and check visually.  <p>B: Valid display range A: Area of 4/16 when measured from the center of B</p> <ul style="list-style-type: none"> Defect in lines: There must be no defect in lines. Defect in pixels: Defect in pixels must be the quantity shown in the table below or less. <table border="1" data-bbox="518 1736 1085 1870"> <thead> <tr> <th>Zone</th> <th>Bright pixel</th> <th>Dim pixel</th> </tr> </thead> <tbody> <tr> <td>A</td> <td>1</td> <td rowspan="2">6</td> </tr> <tr> <td>B</td> <td>3</td> </tr> <tr> <td>Total</td> <td>4</td> <td>6</td> </tr> </tbody> </table> <ul style="list-style-type: none"> Bright pixels: Visible normally through 5% ND filter Dim pixels: Visible normally (Standard: Within the above quantity) 	Zone	Bright pixel	Dim pixel	A	1	6	B	3	Total	4	6	Visual observation
Zone	Bright pixel	Dim pixel											
A	1	6											
B	3												
Total	4	6											



Item	Criteria	Applied tool(s)
LCD and others Self-LED Operation time LED blinks/lights Cancel Brightness	<ul style="list-style-type: none"> • 10 ± 0.5 second • Blinks 9 times and lights for 1 second. (Measure the time until release is done since S2 was ON.) • After start: S20N • Barrier: Closed Mode switch should be changed. (Make sure that cancel can be done by itself.) (Make sure that self-cancel can be done after self-start.) • Blinking can be checked. (Observe LED from the position which is 5m away from it, in the full range of angle of view, outdoors, under the fine weather condition (80000 lux). 	Visual observation Stop watch Visual observation
Electric characteristics Consumption current Stand-by Start (Photography) B. C voltage When voltage decreases • Level 1 • Level 2 • Level 3	<ul style="list-style-type: none"> • When card is not used: 0.19mA or less (when the power switch is OFF) • When card is used: 0.28mA or less (when the power switch is OFF) • 12mA or less (at "Sleep") • 0.75W or less (when the power switch is OFF) • Connect the constant-voltage power supply. Decrease the power supply voltage 1 second before measurement. The voltage is under the following conditions now. Measure the voltage (excluding "When voltage increases"). Level 1 : The battery "half" mark lights on the monitor LCD. Level 2 : The "no battery capacity" warning appears on the monitor LCD. Level 3 : Power OFF • In the case of the voltage at Level 1, also measure the voltage when pressing lightly the shutter release button. • When measuring the voltage at Level 3, the power must be automatically turned off after 30 seconds since the voltage reached Level 2. The voltage must not be regulated. 	Constant voltage power supply Ammeter Constant voltage power supply Volt meter

Item	Criteria	Applied tool(s)
<p>Electric characteristics</p> <p>When voltage increases (Alkaline battery)</p> <ul style="list-style-type: none"> • Level 1 • Level 2 	<ul style="list-style-type: none"> • $3.8 \pm 0.1V$ • $3.4 \pm 0.1V$ 	<p>Constant voltage power supply</p> <p>Volt meter</p>
<p>Regulations of the "half" mark</p>	<p>The rest of battery capacity when the battery "half" mark lights:</p> <ul style="list-style-type: none"> • $20 \pm 10\%$ <p>Rate of the film counter for the "half" mark display against the counter allowing to take all pictures of the film:</p> <ul style="list-style-type: none"> • $85 \pm 5\%$ (25°C) <ul style="list-style-type: none"> • When the voltage increases, the battery mark disappears on the monitor LCD. Check the AC detection level by this disappearance. • Connect the constant-voltage power supply and check the voltage at Level 3 ("no battery capacity" indication). Then, turn off the power, increase the voltage by 0.1V and change the power switch from OFF to ON. The voltage is under the following conditions now. Measure the voltage. (When changing the voltage, turn off the power.) • Level 1 : The battery mark is turned off on the monitor LCD. • Level 2 : The battery "half" mark lights on the monitor LCD. 	<p>Constant voltage power supply</p> <p>Volt meter</p>

[2] 工具一覧表 Tool List

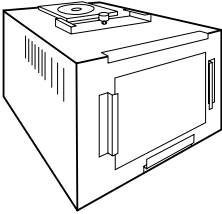

※：新規工具

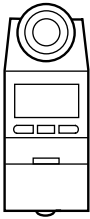
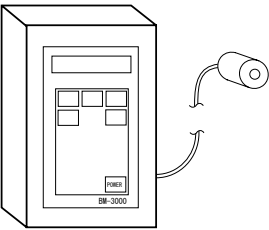

※：New tool

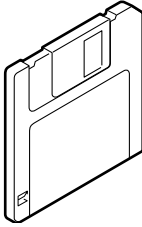

工具番号 Tool No.	名 称 Name	備 考 Remarks
J63080	パターンボックス LV-1450DC Pattern Box LV-1450DC 	共通 (E4300, E3500, E3100, E2100, E5100, E5400, E3700, E3200, E2200, E8700, E8400, E8800, E4100, E4200, E4600, E4800, E5200, E5600, SQ, E5900, E7900, E7600, S1, S2) Common (E4300, E3500, E3100, E2100, E5100, E5400, E3700, E3200, E2200, E8700, E8400, E8800, E4100, E4200, E4600, E4800, E5200, E5600, SQ, E5900, E7900, E7600, S1, S2)
J63080A	交換用ハロゲンランプ (LV-1450DC 用) Spare Halogen Lamp (For LV-1450DC) 	LV-1450DC Exclusive
J63081	カラーメータ (ミノルタカラーメータⅢ F) Color Meter (Minolta Color meter Ⅲ F) 	共通 Common
J63068	輝度計 BM-3000 Luminance Meter BM-3000 	共通 Common

※：新規工具

※：New tool

工具番号 Tool No.	名 称 Name	備 考 Remarks
J65078	キャリブレーションソフト Calibration Software 	共通 (E995, E775, E885, E5000, E2500, E4500, E5700, E4300, E3500, E3100, E2100, E5100, E5400, E3700, E3200, E2200, E8700, E8400, E8800, E4100, E4600, E4800, E5600, E5900, E7600, S1, S2) Common (E995, E775, E885, E5000, E2500, E4500, E5700, E4300, E3500, E3100, E2100, E5100, E5400, E3700, E3200, E2200, E8700, E8400, E8800, E4100, E4600, E4800, E5600, E5900, E7600, S1, S2)
J63090	コリメータ (C-DSC) Collimator (C-DSC) 	共通 Common

工具番号 Tool No.	名 称 Name	備 考 Remarks
※ J15419	エアーリーク試験機 Air leak tester  A stainless steel rectangular device with a pressure gauge on the left side, a handle on top, and two red-handled valves at the bottom. A blue hose is connected to the right side.	
※ J15419-1	エアーリーク試験機用吸着部パッド付 Suction unit with pad for air leak tester  A white rectangular plastic component with a black suction cup in the center and a yellow strap attached to the top.	
※ J15419-2	エアーリーク試験機用クレードルカバー Cradle cover for air leak tester  Two grey plastic components. One is a rectangular cover with a central hole and a protrusion, and the other is a similar component with a different shape and a central hole.	

工具番号 Tool No.	名 称 Name	備 考 Remarks
※J15420	トルクドライバー Torque driver 	
※J15421	ドライバビット Driver bit 	
※FG-50W	グリス Grease 